

SWIMMING POOL INFORMATION				
POOL DIMENSION		UPRIGHT QTY PER POOL	MIN. STEEL WALL YIELD STRENGTH (MPA)	MIN. ALUMINUM WALL YIELD STRENGTH (MPA)
POOL SIZE (D)(ft/m)	POOL RADIUS (ft/m)			
12'(3.66m)	6'(1.83m)	8	REFER TO LATEST POOL WALL DRAWING SPECIFICATIONS 3670-01	N/A
15'(4.57m)	7'6"(2.32m)	10		
18'(5.5m)	9'(2.74m)	12		
21'(6.4m)	10'6"(3.23m)	14		
24'(7.32m)	12'(3.66m)	16		
27'(7.63m)	13'6"(3.815m)	18		
POOL HEIGHT (H)		WATER LEVEL		
52"		46.262"		
54"		48.262"		

TOLÉRANCE GÉNÉRALE / GENERAL TOLERANCE	
PROCÉDÉ / PROCESS	ASSEMBLY/N/A
DEC.	N/A
ANGLE	N/A
UNITS:	INCH (MM)
REF. SCALE	
DROITS D'AUTEUR / COPYRIGHT LE PRÉSENT DOCUMENT ET TOUTES INFORMATIONS AFFÉRENTES SONT LA PROPRIÉTÉ UNIQUE DU GROUPE VIF INC. TOUTE REPRODUCTION EN TOUT OU EN PARTIE EST INTERDITE SANS L'AUTORISATION ÉCRITE DU CLIENT. ALL INFORMATION CONTAINED OR PERTAINING TO THIS DOCUMENT IS THE SOLE PROPERTY OF GROUPE VIF INC. ANY REPRODUCTION IN PART OR AS A WHOLE WITHOUT THE WRITTEN AUTHORIZATION OF THE CLIENT IS FORBIDDEN.	

		4000 Boul. Casavant Ouest, Saint-Hyacinthe, (Quebec) Quebec, Canada, J2S 9E3 T (450) 774-6953 F (450) 774-4970	
PROJET / PROJECT: COMPLIANCE TO APSP-4			
DESCRIPTION: S300 SERIES SWIMMING POOLS 52" - 54"			
NO. PIÈCE / PARTNO:	N/A	VOLUME:	N/A
MATÉRIAU / MATERIAL:	N/A	POIDS / WEIGHT:	N/A
FINITION / FINISH:	N/A	REV:0	
DESS. PAR / DRAW BY:	BLAMBERT	DATE:	2025-06-11
APP. PAR / APP. BY:	SEE PAGE 3	DATE:	SEE PAGE 3
DWG SIZE	B	ECHELLE / SCALE:	N/A
		PAGE / SHEET	1 OF 3

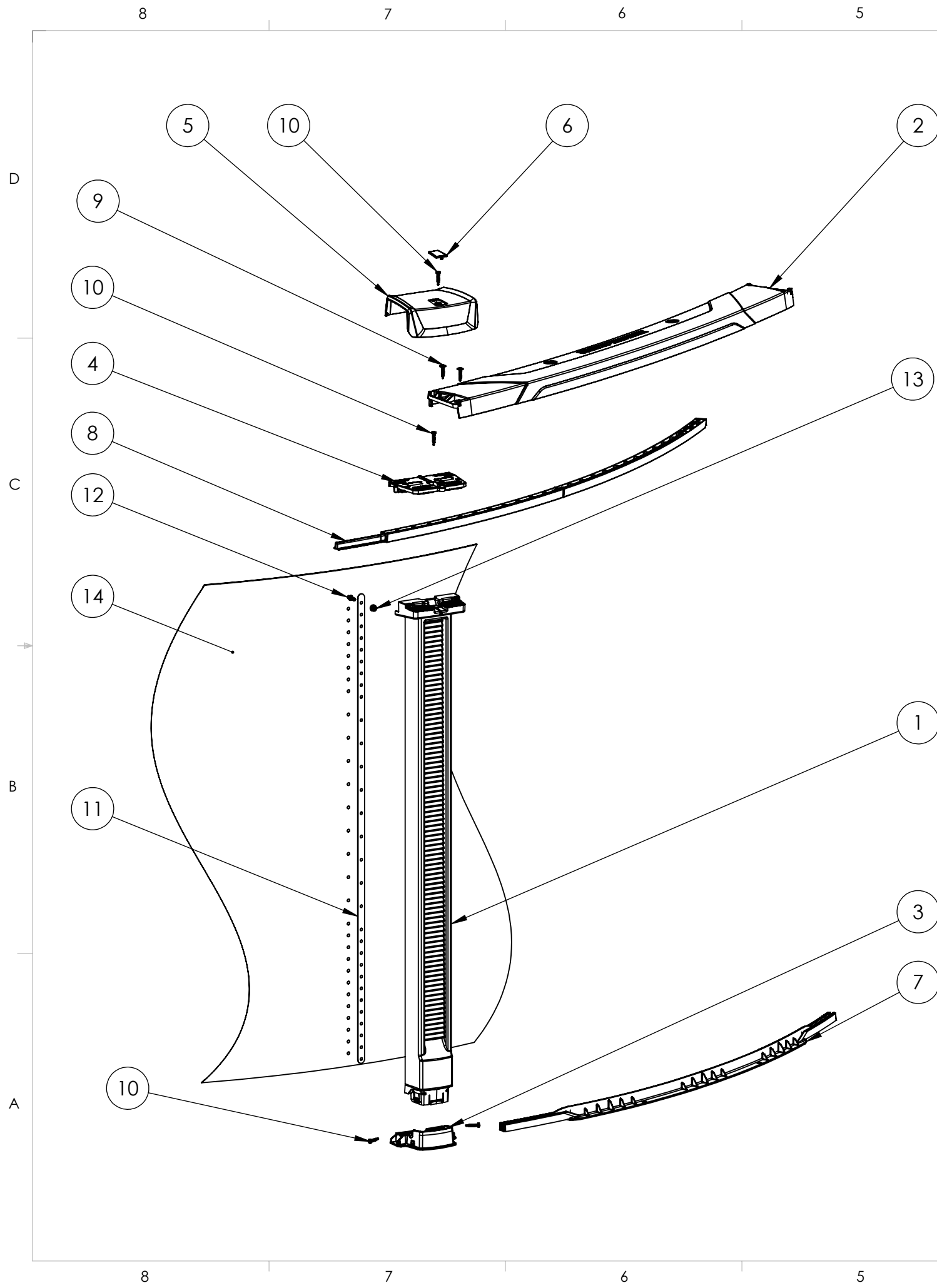

ITEM #	PART CODE	DESCRIPTION	Quantity Per Size					
			12'	15'	18'	21'	24'	27'
1	PS300U52 PS300U54	POOL S300 UPRIGHT 52"/ 54"	8	10	12	14	16	18
2	PS300L	POOL S300 TOP SEAT	8	10	12	14	16	18
3	PS3ZPB	POOL S3 MULTI SERIES BOTTOM PLATE	8	10	12	14	16	18
4	PS3ZPT	POOL S3 MULTI SERIES TOP PLATE	8	10	12	14	16	18
5	PS300C	POOL S300 COVER	8	10	12	14	16	18
6	PS3ZCC	POOL S3 MULTI SERIES COVER CAP	8	10	12	14	16	18
7	PSBR15	POOL SILVER BOTTOM RAIL 15'	8	10	12			
	PSBR24	POOL SILVER BOTTOM RAIL 24'				14	16	18
8	PSTR15	POOL SILVER TOP RAIL 15'	8	10	12			
	PSTR24	POOL SILVER TOP RAIL 24'				14	16	18
9	14455110	TYPE HI-LO THREAD SELF TAPPING SCREW W/WASHER 5/8 SS 316 PASSIVATION #2 #12-14 X 1-1/4"	32	40	48	56	64	72
10	14455032	PAN HEAD #3 SCREW #12-14 X 1,25" SS316	32	40	48	56	64	72
11	02581536	WALLBRACKET 52"	2	2	2	2	2	2
	02581541	WALLBRACKET 54"	2	2	2	2	2	2
12	14172209	PHILLIPS PAN HEAD 1/4"-20 X 3/4", MIN YIELD 80 KSI	52"	30	30	30	30	30
		54"	32	32	32	32	32	32
13	14072620	FLANGED NUT 1/4"-20 X 15/64", MIN YIELD 80 KSI	52"	30	30	30	30	30
		54"	32	32	32	32	32	32
14	SEE PAGE 3	POOL WALL	SEE PAGE 3					

TOLÉRANCE GÉNÉRALE / GENERAL TOLERANCE			4000 Boul. Casavant Ouest, Saint-Hyacinthe, (Quebec) Quebec, Canada, J2S 9E3 T (450) 774-6953 F (450) 774-4970	
PROCÉDÉ / PROCESS	N/A		PROJET / PROJECT: COMPLIANCE TO APSP-4	
DEC.	N/A	DESCRIPTION: S300 SWIMMING POOLS 52"-54"		
ANGLE	N/A	NO. PIÈCE / PARTNO: N/A	VOLUME: N/A	
UNITS: INCH (MM)		MATÉRIAU / MATERIAL: N/A	POIDS / WEIGHT: N/A	
REF. SCALE		FINITION / FINISH: N/A	REV: 0	
DROITS D'AUTEUR / COPYRIGHT		DESS. PAR / DRAW BY: BLAMBERT	DATE: 2025-06-11	
LE PRÉSENT DOCUMENT ET TOUTES INFORMATIONS AFFÉRENTES SONT LA PROPRIÉTÉ UNIQUE DU GROUPE VIF INC. TOUTE REPRODUCTION EN TOUT OU EN PARTIE EST INTERDITE SANS L'AUTORISATION ÉCRIT DU CLIENT.		APP. PAR / APP. BY: SEE PAGE 3	DATE: SEE PAGE 3	
ALL INFORMATION CONTAINED OR PERTAINING TO THIS DOCUMENT IS THE SOLE PROPERTY OF GROUPE VIF INC. ANY REPRODUCTION IN PART OR AS A WHOLE WITHOUT THE WRITTEN AUTHORIZATION OF THE CLIENT IS FORBIDDEN.		DWG SIZE: B	ECHELLE / SCALE: N/A	PAGE / SHEET: 2 OF 3

REVISIONS				
REV.	DESCRIPTION	DATE	DRAWN BY	APPROVED BY
0	INITIAL RELEASE	2025-06-11	BLAMBERT	REFER TO WORK RESPONSIBILITIES TABLE

ROUND ALUMINUM WALL CONFIGURATION 54"									
ITEM#	54"	POOL SIZE	12'	15'	18'	21'	24'	27'	
14	PWA255412WSTD	12'	1						
	PWA255412GSTD		1						
	PWA285412WSTD		1						
	PWA285412GSTD		1						
	PWA325412WSTD		1						
	PWA325412GSTD		1						
	PWA255415WSTD	15'		1					
	PWA255415GSTD			1					
	PWA285415WSTD			1					
	PWA285415GSTD			1					
	PWA325415WSTD			1					
	PWA325415GSTD			1					
	PWA255418WSTD	18'			1				
	PWA255418GSTD				1				
	PWA285418WSTD				1				
	PWA285418GSTD				1				
	PWA325418WSTD				1				
	PWA325418GSTD				1				
	PWA255421WSTD	21'				1			
	PWA255421GSTD						1		
	PWA285421WSTD						1		
	PWA285421GSTD						1		
	PWA325421WSTD						1		
	PWA325421GSTD						1		
	PWA255424WSTD	24'					1		
	PWA255424GSTD							1	
	PWA285424WSTD							1	
	PWA285424GSTD							1	
	PWA325424WSTD							1	
	PWA325424GSTD							1	
	PWA255427WSTD	27'						1	
	PWA255427GSTD								1
	PWA285427WSTD								1
	PWA285427GSTD								1
	PWA325427WSTD								1
	PWA325427GSTD								1

ROUND STEEL WALL CONFIGURATION 52"								
ITEM#	52"	POOL SIZE	12'	15'	18'	21'	24'	27'
14	PWS175212WSTD	12'	1					
	PWS175212GSTD		1					
	PWS175215WSTD	15'		1				
	PWS175215GSTD				1			
	PWS175218WSTD	18'			1			
	PWS175218GSTD					1		
	PWS175221WSTD	21'				1		
	PWS175221GSTD						1	
	PWS175224WSTD	24'					1	
	PWS175224GSTD							1
	PWS175227WSTD	27'						1
	PWS175227GSTD							



WORK RESPONSIBILITIES TABLE	
TECHNICAL DRAWING REPRESENTING THE DESIGN CARRIED OUT BY VIF DATED 2025-05-12, DRAWN BY:	BENOIT LAMBERT
DRAWING PRODUCED UNDER THE SUPERVISION OF:	JUAN F. HENAO P.ENG, M.SC.A.
MATERIALS AND DIMENSIONS IN DRAWING ARE CONSISTENT WITH THE STRUCTURAL ANALYSIS PRESENTED IN REPORT: "2001453-01-1_A_STRUCTURAL-ANALYSIS-ON-OVAL-AND-ROUND-POOLS.PDF"	JUAN F. HENAO P.ENG, M.SC.A.

TOLÉRANCE GÉNÉRALE / GENERAL TOLERANCE		4000 Boul. Casavant Ouest, Saint-Hyacinthe, (Québec) Québec, Canada, J2S 9E3 T (450) 774-6953 F (450) 774-4970
PROCÉDÉ / PROCESS	N/A	
DEC.	N/A	PROJET / PROJECT:
		COMPLIANCE TO APSP-4
		DESCRIPTION:
		S300 SWIMMING POOLS 52"-54"
ANGLE	N/A	NO. PIÈCE / PARTNO:
		N/A
		VOLUME:
		N/A
		MATÉRIAU / MATERIAL:
		N/A
		POIDS / WEIGHT:
		N/A
		FINITION / FINISH
		N/A
		REV:0
		DESS. PAR / DRAW BY: BLAMBERT
		DATE: 2025-06-11
		APP. PAR / APP. BY: SEE PAGE 3
		DATE: SEE PAGE 3
DWG SIZE	B	ECHELLE / SCALE:
		N/A
		PAGE / SHEET
		3 OF 3

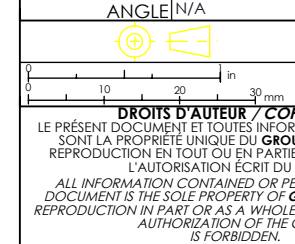

DROITS D'AUTEUR / COPYRIGHT
 LE PRÉSENT DOCUMENT ET TOUTES INFORMATIONS AFFÉRENTES SONT LA PROPRIÉTÉ UNIQUE DU GROUPE VIF INC. TOUTE REPRODUCTION EN TOUT OU EN PARTIE EST INTERDITE SANS L'AUTORISATION ÉCRITE DU CLIENT.
 ALL INFORMATION CONTAINED OR PERTAINING TO THIS DOCUMENT IS THE SOLE PROPERTY OF GROUPE VIF INC. ANY REPRODUCTION IN PART OR AS A WHOLE WITHOUT THE WRITTEN AUTHORIZATION OF THE CLIENT IS FORBIDDEN.