

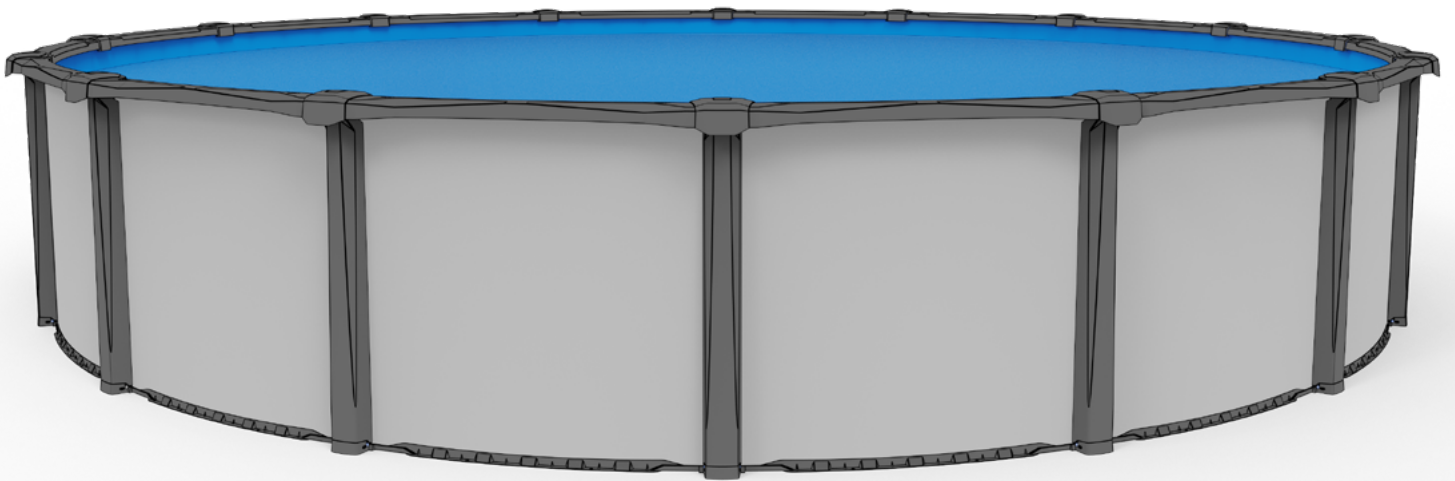

## USER GUIDE ROUND POOLS

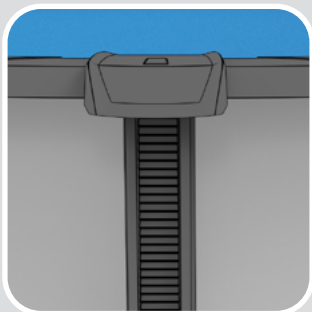

### SERIES 3



MODEL 300

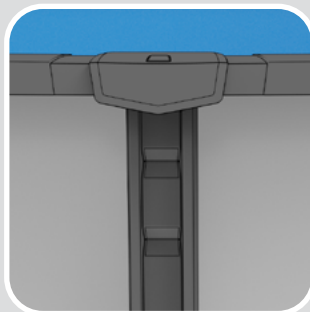

MODEL 310

### SERIES 5



MODEL 500

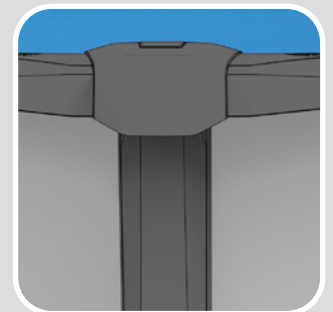

MODEL 510

## TABLE OF CONTENTS

<b>INTRODUCTION</b>	<b>2</b>
<b>WARNINGS</b>	<b>3</b>
<b>INSTALLATION</b>	<b>4</b>
<b>POOL LOCATION</b>	<b>4</b>
<b>THE FOUNDATION</b>	<b>6</b>
<b>WALL INSTALLATION</b>	<b>8</b>
<b>INSTALLATION OF THE GEOTEXTILE MAT</b>	<b>10</b>
<b>STRUCTURE INSTALLATION (GENERAL)</b>	<b>10</b>
<b>LINER INSTALLATION (GENERAL)</b>	<b>10</b>
<b>INSTALLATION OF SPECIFIC STRUCTURES</b>	<b>11</b>
<b>SERIES 5</b>	<b>12</b>
<b>SERIES 3</b>	<b>14</b>
<b>FIXING BOTTOM PLATES TO THE STRUCTURE</b>	<b>16</b>
<b>FILLING THE POOL</b>	<b>16</b>
<b>INSTALLING SAFETY STICKERS</b>	<b>17</b>
<b>FOUNDATION DRAINAGE PROTECTION</b>	<b>18</b>
<b>INSPECTION</b>	<b>18</b>
<b>WINTERIZING THE POOL</b>	<b>18</b>
<b>SPRING OPENING</b>	<b>20</b>
<b>REPLACEMENT PARTS</b>	<b>21</b>

## INTRODUCTION

Thank you for purchasing a SUNLAB™ round above-ground pool.

We want to help you get the best results from your new product and operate it safely. This manual contains information on how to proceed; please read it carefully before installing and using the pool. If you have any problems or questions about your product, please consult an authorized SUNLAB™ dealer or distributor.

All information contained in this manual is based on the latest information available at the time of publication. The manufacturer reserves the right to make changes at any time without notice and without incurring any obligation. No part of this publication may be reproduced without written permission.

## READ AND FOLLOW ALL INSTRUCTIONS

Review all instructions supplied with the product before installation, start-up, operation, shut-down, maintenance or winterization.

Failure to comply with warnings and safety messages may result in property damage or personal injury. The user assumes all risks to persons or property resulting from any misuse of this product.

## IMPORTANT SAFETY INSTRUCTIONS

### YOUR SAFETY AND THAT OF OTHERS IS VERY IMPORTANT.

This manual provides important safety messages. A safety message alerts you to potential hazards that could injure you or others. Each safety message is identified by a black box and one of three words, DANGER, WARNING or CAUTION.

## CERTIFICATION AND COMPLIANCE

**When installed in accordance with the specifications outlined in this user manual, the configurations listed on the ICC listing comply with the following standards and safety codes :**



ICC-ES File PMG-1576  
ANSI/PHTA/ICC-4 standards  
Standard for above-ground pools / Residential above-ground pools

2024, 2021, 2018, 2015, and 2012 International Building Code® (IBC)  
2024, 2021, 2018, 2015, and 2012 International Residential Code® (IRC)  
2024, 2021, 2018 and 2015 International Swimming Pool and Spa Code® (ISPSA)  
2023, 2020 and 2017 City of Los Angeles Building Code® (LABC)  
2023, 2020 and 2017 City of Los Angeles Residential Code® (LARC)  
2023, 2020 and 2017 Florida Building Code® (FBC)  
2023, 2020 and 2017 Florida Residential Code® (FRC)  
2022, 2019, 2016, and 2013 California Building Code® (CMC)  
2022, 2019, 2016, and 2013 California Residential Code® (CRC)  
2024, 2021, 2018, 2015, and 2012 Uniform Swimming Pool, Spa and Hot Tub Code (USPSHC)\*

\*Copyrighted publication of the International Association of Plumbing and Mechanical Officials.

## WARNING

Your pool is an area of fun, refreshment and relaxation for family and friends. It's designed to be safe and to last for many years. However, careless use of your pool can quickly become dangerous. Pools are subject to wear and tear. If not properly maintained, certain types of excessive or accelerated deterioration can cause the pool structure to fail, releasing large quantities of water that can cause personal injury and property damage. Your pool contains enough water and is deep enough to represent a real danger to its users. That's why it's important to follow and enforce the safety instructions strictly, to ensure safe use of this product. Failure to follow the recommendations listed below may result in serious injury, paralysis or even death.

We recommend that you take a first-aid course that includes CPR, or refresh your knowledge of the subject, so that you can react quickly to any incident. Make sure you're aware of the regulations governing pool use in your municipality. Publications describing the risks of drowning, entrapment and diving accidents are available.

## SAFETY RECOMMENDATIONS

- **Make sure all pool users know and follow the recommendations.**
- **Do not dive or jump.** Your above-ground pool is not deep enough to allow safe diving or jumping. This can result in concussion, paralysis, drowning or death.
- **Don't run or fight near the pool.** When surfaces become wet and slippery, falls can occur, causing serious injury.
- **Never leave children unsupervised.** It only takes a few seconds for a child to drown.
- **Restrict access to the swimming pool** ensuring that the ladder is removed, or raised. A barrier is necessary to protect against drowning and near-drowning. Gates are no substitute for constant supervision of children. If you have a deck overlooking your pool, you must have a door fitted with an automatic locking system to restrict access to the water. Don't leave garden furniture around the pool that could allow access to the water. Objects such as toys, chairs, tables or similar items that a small child could climb on must be at least 4' (1219 mm) from the pool. Your filtration system (pump and filter) should be at least 4' (1219 mm) from the edge of your pool. Consult your municipal regulations.
- **Life-saving equipment** should always be present and accessible near the pool: either a 16' (4.88m) pole with a prehensile tip and/or a 1/2" diameter, 50' rope attached to a 15" OD buoy. Poor swimmers should always use a personal life jacket.
- **Wait 1 hour after eating before swimming.** Cramps can occur, leading to the risk of drowning.
- **Do not walk or sit on ledges** as they were not designed for this purpose. They can be slippery, leading to dangerous falls.
- **Do not consume alcohol or drugs** which can distort your judgment and impair your reflexes.
- **Do not use your pool if the bottom is not visible.** It must be visible at all times from the outside perimeter of the pool. At night, it should always be adequately illuminated.
- **Do not use glass bottles or containers** near the pool. These can cause serious personal injuries or damage to the pool.
- **Do not use your pool during thunderstorms.**
- **Keep your pool clean and hygienic,** as it could cause illness.
- **Do not swim alone.** If something happens to you, no one will be able to help.
- **A list of emergency phone numbers,** such as police, fire, ambulance and/or the nearest available rescue units. These numbers should be kept near the telephone closest to the pool.

## ELECTRICAL CONNECTION AND GROUNDING OF THE POOL

Once your pool is installed, electrical bonding and grounding are important safety features. Your pool water, all metal components and your body are all conductors and can carry electricity in certain situations. A bonded pool keeps all currents flowing outwards in a bonding wire or grid, where they are safely dispersed.

Check with your installer or retailer about compliance codes in your area to meet the requirements for proper bonding and grounding of your pool and installations.

## OTHER RECOMMENDATIONS

**Keep an eye on your pool liner.** If your liner is a few years old, worn, punctured, discolored or you think it may have been over-chlorinated, it could be defective and cause structural damage

to your pool. Please contact a specialist if you have any doubts about the durability of your liner.

**Keep an eye on your pool and its equipment.** Water leaks around the pool can quickly cause structural damage to the pool. Please contact a specialist if you have any doubts about the plumbing, bottom drain, skimmer, water return, etc. Regularly check your water inlet and skimmer seals to make sure there are no water leaks.

**Keep an eye on the ground around your pool.** Make sure that the ground around your pool is always stable and well compacted, and that no building gutters run down to it. Weakened ground around the pool can quickly lead to structural damage. Please contact a specialist if you have any doubts about the ground on which your pool rests.

**Beware of decks near the pool.** Be sure to contact a specialist when your deck is located near the pool, as improper installation, drainage, positioning, construction or shape could result in structural damage to the pool. If in doubt, contact an installation specialist or your dealer. Damage to the pool caused by a deck will automatically void the manufacturer's warranty.

## THIRD-PARTY INSTALLATION

Groupe VIF inc. is not responsible for any problems related to the installation of the pool. Any materials, practices, steps, tools or parts that differ from this manual will result in the automatic cancellation of the manufacturer's warranty and the manufacturer's liability.

## UNPACKING THE POOL PARTS

Before starting, open all the boxes supplied with your pool. Lay them out on the ground and make sure you have all the parts listed in the material lists at the end of this manual. Never begin installation if any parts are missing, damaged or broken. If this is the case, contact your retailer, who will supply you with the missing parts or replace the defective ones. Once the installation is complete, it is assumed that the parts have been inspected and were in good condition at the time of delivery.

**N.B. Under no circumstances should the pool wall be detached and unrolled before the bottom rails have been assembled, as this will be very difficult to handle and install.**

# INSTALLATION

Before starting installation, make sure you have all the tools and materials listed below. Check the contents of the boxes containing the pool parts and make sure that everything is included before beginning installation. All parts in the boxes are important and must be properly installed in the right places. If they are omitted or interchanged, they could cause the pool to fail. Once started, pool installation should be completed as soon as possible. If a part is defective, damaged or missing, contact the SUNLAB™ retailer where you purchased your pool.

## ⚠️ WARNING

The product warranty will be void if all installation requirements and instructions contained in this manual are not followed. Some assembly methods differ from one model to another, so please read the particularities carefully.

## TOOLS

- Shovel
- Garden hose
- Hammer
- Rubber mallet
- Soil compactor (manual or mechanical)
- Laser or water transit level or 6-foot minimum linear level
- Pliers
- Vacuum cleaner
- Gardening rake
- Measuring gallon
- Drill
- Ratchet wrench, adjustable wrench and torque wrench (Torque 8.5 N-m (75 lbf-in))
- Phillips or Robertson #3 screwdriver bit
- Hexagonal socket 7/16"
- Wheelbarrow
- Punch 3/16" diameter
- Step ladder
- Vinyl-coated hooks, rope and tent pegs
- Workshop broom

## REQUIRED MATERIAL

- 2" Duct tape
- 8" to 12" rod or nails (number of uprights + 1)
- Compaction sand or rock dust or both (see table below)
- River rocks or stones (3/4" minimum)
- Solid Concrete Block 8"x16"x4". (Quantities equal to number of pool posts) (optional)
- Synthetic fiber geotextile pool mat cut to the size of your pool.
- (2X) sheets of 3' x 3' plywood 1/2" thick minimum
- Flexible cardboard 16" X 9"
- 2" x 4" of wood 1 foot longer than the pool radius
- SUNLAB™ swimming pool parts
- (1X) Can of brightly colored spray paint
- SUNLAB™ pool parts

## ⚠️ WARNING

The use of any material other than that specified for the installation of this pool could accelerate the deterioration of the pool.

### INFORMATION REQUIRED FOR POOL INSTALLATION

POOL SIZE (FEET)	12'	15'	18'	21'	24'	27'	30'	33'
POOL RADIUS	6'	7'6"	9'	10'6"	12'	13'6"	15'	16'6"
FOUNDATION RADIUS TURF REMOVAL	7'	8'6"	10'	11'6"	13'	14'6"	16'	17'6"
AGGREGATE REQUIRED FOR FOUNDATION (IN TONS)*	1 to 1.5	1.5 to 2	2.5 to 3	3.5 to 4	4 to 4.5	5 to 6	6 to 7.5	7 to 8

\* The aggregate required for the foundation should be the finest possible stone dust and/or compaction sand. The quantity of aggregate required may vary depending on the quality and straightness of the ground on which the pool will be laid.

## REQUIRED POOL EQUIPMENT

A basic circulation and filtration system **MUST BE INSTALLED** as follows:

- A skimmer
- A pool pump
- A filter
- A water inlet
- A bottom drain (optional)

We recommend that you have your circulation and filtration system installed by certified installers. Contact your retailer or dealer.

## IMPORTANT TO CONSIDER BEFORE INSTALLATION

**We strongly advise you to hire installers recommended by your dealer.** If you decide to install your pool yourself, we recommend a minimum of 3 people.

## ⚠️ WARNING

Follow the installation steps and recommendations carefully without omitting any. Serious injury and/or material damage may occur.

1. The installation steps in this manual assume that the ground is perfectly straight.
2. In the event of a steeply sloping site, or if you require slopes in your pool and/or a bottom drain, we recommend that you contact an installation professional.
3. Your pool must be perfectly level: once installed, your pool's foundation must have a maximum 1/4" difference in level from one end of the pool to the other, regardless of size.

## POOL LOCATION

## ⚠️ WARNING

Your installation must comply with the codes of the authorities having jurisdiction in your area. You may need building, plumbing, electrical, zoning or other permits. Check your local bylaws before beginning installation, as they may affect your choice of pool location.

## GENERAL TOPOGRAPHY AND SITE DRAINAGE

**The first and most important step is to choose the ideal location for your pool. This will determine the longevity of your pool.**

- Ground leveling is crucial. If the pool is more than 1/4" sloped, it will put more weight on the low side, and this uneven weight distribution can cause the low side to sink further, lead to buckling of the studs or add additional stress to the wall, or even cause it to break.
- The site must drain well and be solid. It must slope positively (i.e. away from the pool) and not form depressions, as this would result in water accumulation, compromising your foundation and possibly damaging your pool. You should have at least 6 feet of positive slope around the pool. If you have any questions about the slopes on your property, please consult an experienced installer or your dealer.

## TYPES OF PROHIBITED INSTALLATIONS

- Do not bury your above-ground pool. This will automatically void the warranty. Your above-ground pool is not designed to be partially or completely buried. The pool wall draws its strength from the pressure of the water pushing evenly outwards against the wall.
- Backfill provides poor support under the pool, so you should always dig the high side to level the ground, rather than adding sand or soil to the low side to build it up. Backfilling will void the warranty.
- The soil must be free of rocks, stones and tree roots.
- Never install your pool directly on concrete, asphalt, tar paper, grass, peat moss, wood, gravel, earth or clay.
- Position your pool away from trees, power lines or cables, clotheslines and buildings (house, garage, etc.). Bathers could use them to dive in or get caught, causing serious injuries.
- Never install your pool over underground power lines, gas lines or septic tanks.
- Make sure that none of the building's gutters drain onto your pool's foundation.
- If your pool is located near a deck, it's important to drain the area underneath the deck near the pool.
- It is not recommended to finish a pool deck on top of ledges. If it is, it should be spaced vertically at least 4 inches from the pool.

- The pool must be located at least 6 feet (1.83 m) from any electrical outlet. All 125-volt, 15 and 20 amps outlets within 20 ft (6.0 m) of the pool must be protected by a ground-fault circuit interrupter (GFCI). The 20 ft (6 m) distance is measured via the shortest straight line distance the power cord would follow without piercing a floor, wall, ceiling, door, window or other permanent barrier.
- An installation should never be made on unstable ground, with drainage problems or significant ground movement, or within 33 feet of a tree.

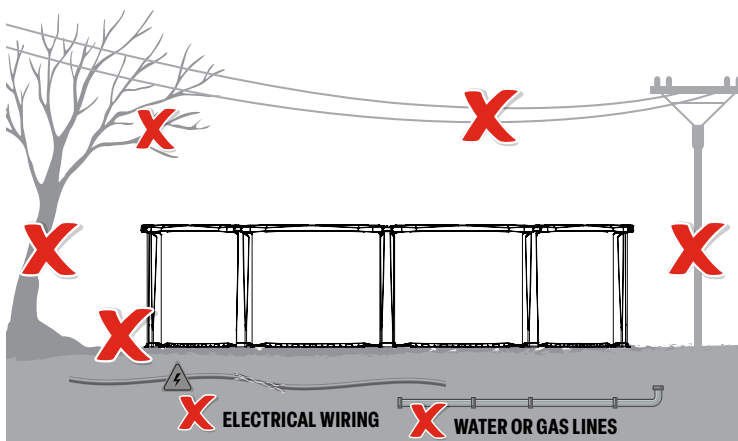
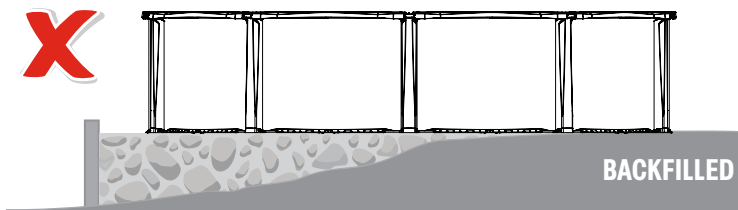
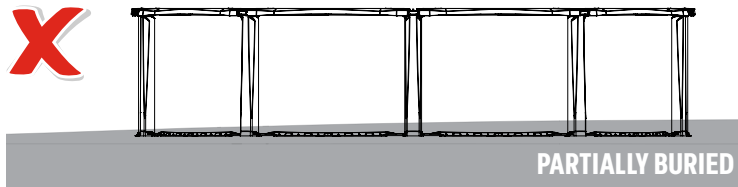
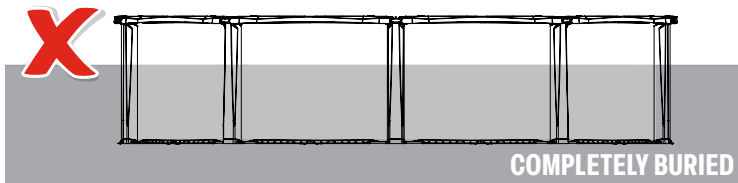
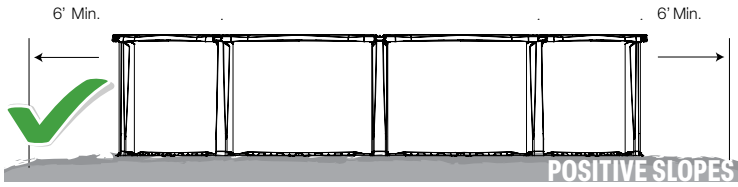

## SITE DRAINAGE

Whether it's because it's a new installation, your site is located in a low-lying area of your land, the presence of water veins or simply because your land is poorly drained, you may need to consider installing additional drainage to keep water away from the perimeter of your pool. In all cases, these installations should be handled by professionals.

## CORROSION-RELATED PROBLEMS

**It is important to avoid environments that promote corrosion, such as prolonged or permanent exposure to stagnant water. Metal components, such as the wall, must be allowed to dry. Corrosion caused by failure to comply with the recommendations listed below will not be considered a manufacturing defect:**

- Do not bury your above-ground pool. Your above-ground pool is not designed to be partially or completely buried. The pool wall must never be in direct contact with the ground or water. The top of the bottom rails must always be visible outside the pool.
- Never install your pool where chemicals have been applied, as this can damage your liner and corrode the pool wall.
- Never install your pool directly on the ground; it should always be installed on a base that drains, such as compaction sand or fine rock dust.
- Never use organic materials that retain moisture under or around your pool, such as: peat moss as a base under your liner, mulch or soil around the outside of your pool for landscaping, etc.
- Choose a location that is not in a depression where water collects, near a slope where there is freeze-thaw or rain runoff, where the soil has drainage problems, in a flood zone or where there are underground water veins.
- Check frequently for leaks in the liner, water inlet and skimmer, and make sure that your filtration system is watertight. Avoiding of checking these points is considered negligence.
- Check the pool wall regularly for impacts or scratches caused by objects such as rocks, lawnmowers, edgers or other objects. These damage the wall's protective finish and initiate corrosion which, over time, will deteriorate the pool wall.

# THE FOUNDATION

The foundation is the most important part of the pool installation. It will support your pool for many years to come. So it's important to be meticulous and to take your time. The flatness and compaction of the foundation will have a decisive impact on the longevity of the pool.

## STEP 1

Mark the center of your pool with a stake (taking into account your municipal code regulations and your existing installations: deck, patio, etc.). Under no circumstances should you remove the center stake until step 12.

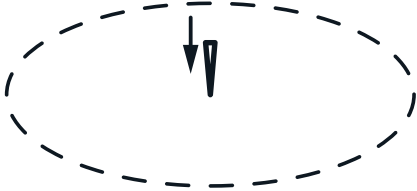

## STEP 2

Mark out the area to be cleared using the measuring gallon and spray paint. Attach the gallon (or rope of required length) to the center stake. Measure the radius of the pool plus 12" (30cm), then outline the circle with spray paint.

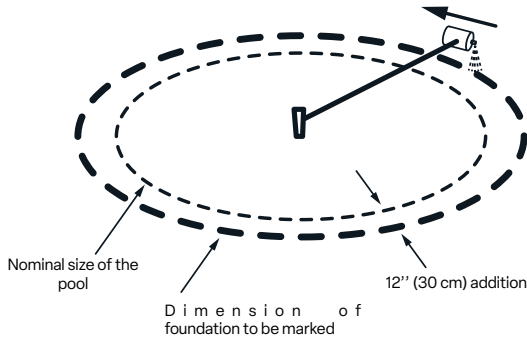

## STEP 3

The best way to level the ground and remove the grass is to start at the lowest point of the installation surface. Make sure the pool is installed on hard ground. It is not advisable to add soil to level the surface, but rather to scrape off the high spots, as this soil will compact once the pool is full of water, destabilizing the level of the pool and possibly causing damage. You will need to remove all branches, roots, stones and weeds from the installation area. These could damage your liner and your pool.

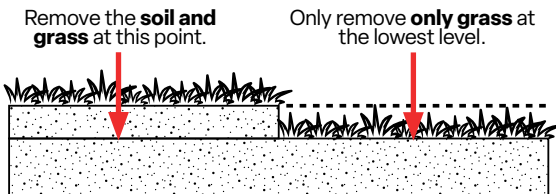

## STEP 4

Level the inside of the circle using a garden rake, a carpenter's level and a plank the length of the radius of the pool plus 12" (straight) to smooth the surface. Don't add soil! It will never be as compact as the existing soil. Rake the existing soil. Compact the soil 2 times using a mechanical compactor. When compacting, start from the center outwards in a circular pattern.

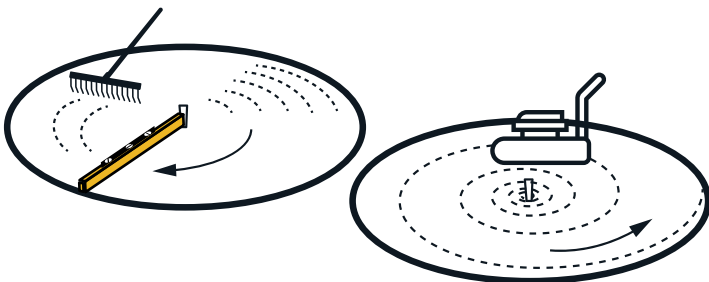

## STEP 5

Check flatness with a transit, water or linear level, and make sure your floor is level. Check your floor like a grid every 3" to 5". The larger your pool, the more measurements you'll need to take. Check again to make sure there are no furrows, stones, branches or roots. A maximum difference in level of 1/4" (6 mm) is allowed from one end of the pool to the other. (You can also use a laser level, an optical level or a water level to make sure everything is flat.)

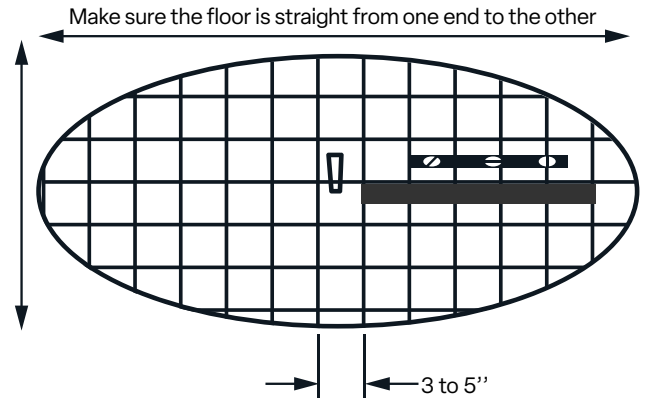

**WARNING** Any pool installed improperly, not following the floor recommendations and/or the installation steps may shorten the life of the pool, represent a danger of serious injury to users and/or material damage.

## STEP 6

Place mounds of aggregate every 4' on the perimeter of the pool size line and spread them out in the next step.

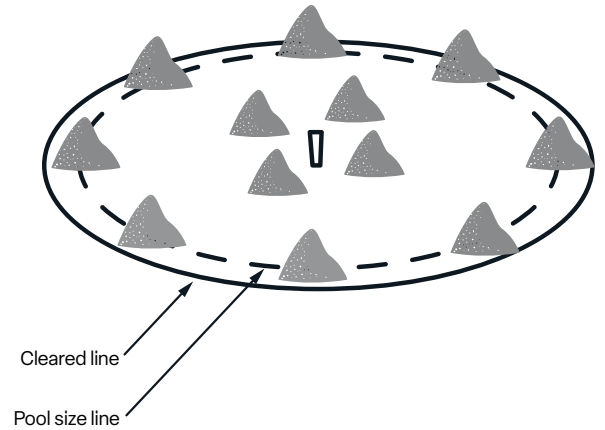

## STEP 7

Spread the aggregate around the line of the pool to a width of 16". That is, 8" outside and 8" inside your pool's dimension line. The thickness of the uncompacted aggregate should be between 4 and 5 inches. Once compacted, it should be no more than 2 to 3" thick. Use the plank on the central stake and a carpenter's level to even out the aggregate. Adjust the height of the central post to achieve the desired result.

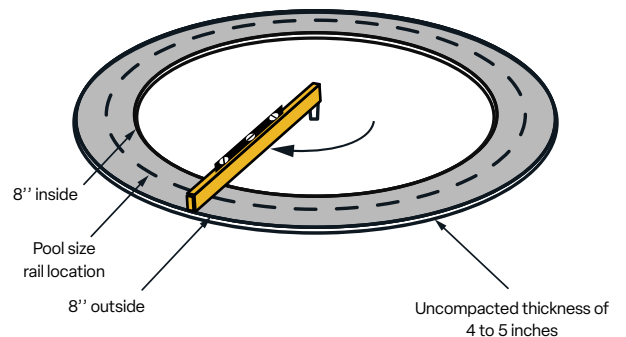

**STEP 8**

Moisten and compact the outer perimeter aggregate twice using a compactor. Measure the flatness and thickness of the aggregate in the circle. The base of your pool should rest on a flat surface with no gaps under the feet or rails. The maximum difference in level allowed is 1/4 inch. If the flatness and thickness are not adequate, start over. Place piles of aggregate in the center to form the base in a subsequent step.

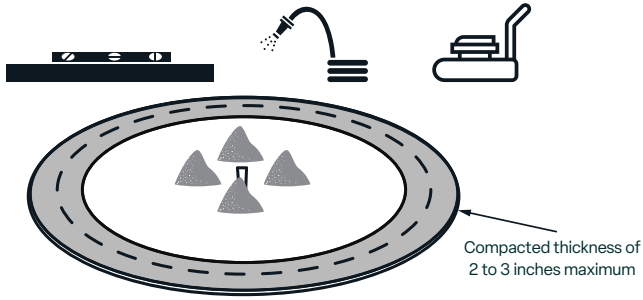

**STEP 9**

Place the rails and feet on the dimension line of your pool and connect them together. Do not press the rail into the bottom of the foot. The rail has a graduated scale at each end. Set it to number 5 (on the dimmer), which will give you approximately 1/2" to 5/8" clearance between the middle of the foot and the end of the rail. The spacing between the two rails and the center of the foot **should be equal on both sides at all times**, even if it sometimes varies from foot to foot. **The gradation section of the rail must be below the arrow of the bottom plate at all times so that the structure remains secure. The hatched area at the end of the rails must never be visible at any time.**

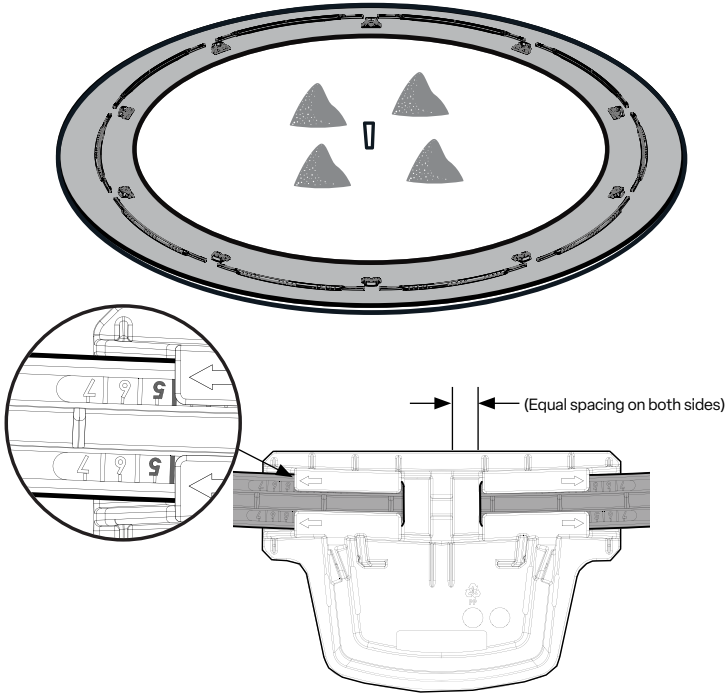

**STEP 10**

Spread the 4 to 5 inches of uncompacted aggregate inside the "pool" area so that it is equal to the already compacted area outside. If you do not have enough aggregate, now it would be the time to bring more. This area will be compacted in a subsequent step, just before the liner is installed. Don't forget to save some aggregate for the cove.

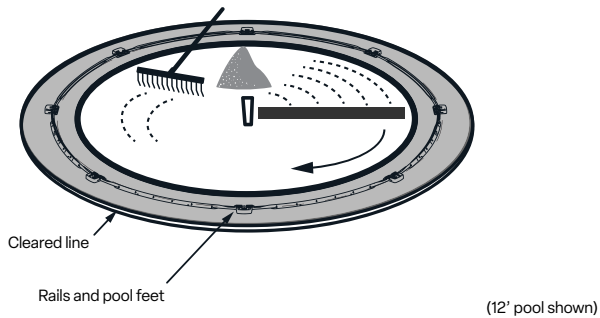

**STEP 11**

Measure from the center of the pool to the inside of the rail groove. Take a measurement to the left and right of each foot. The distance should be equal to the radius of the pool. When the measurement is correct, drive an 8" nail or rod against the outside center of each foot to prevent movement and keep a reference. See diagram below for exact nail location.

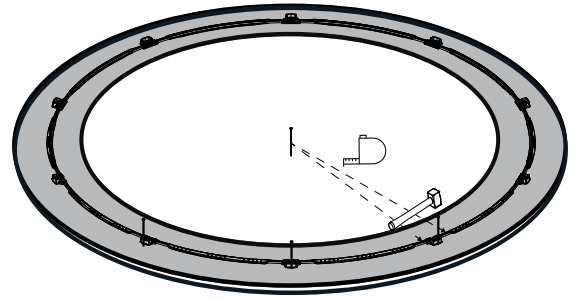

Example of a 12' Pool = 6' (72") radius

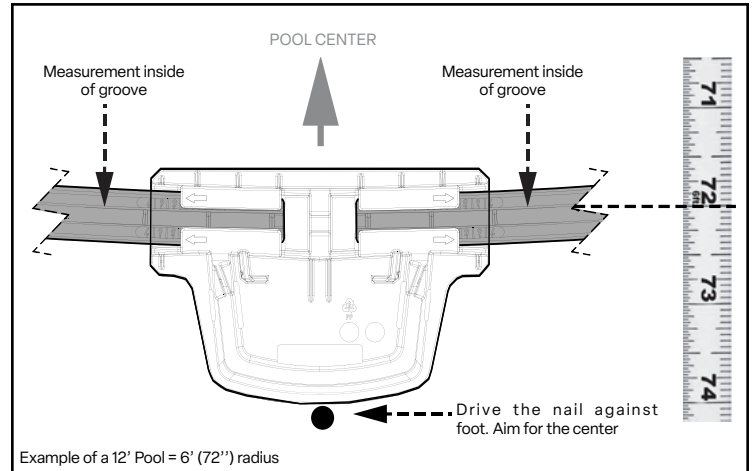
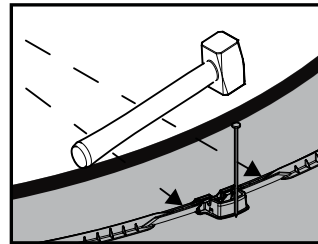

**STEP 12**

To confirm step 11, measure the diagonal between each foot. If your pool is round, all your measurements will be identical, i.e. equivalent to the diameter of your pool (for a 12' pool = 12'). Under no circumstances should you skip this step, as an egg-shaped pool will work poorly over time and could cause future problems, even burst.

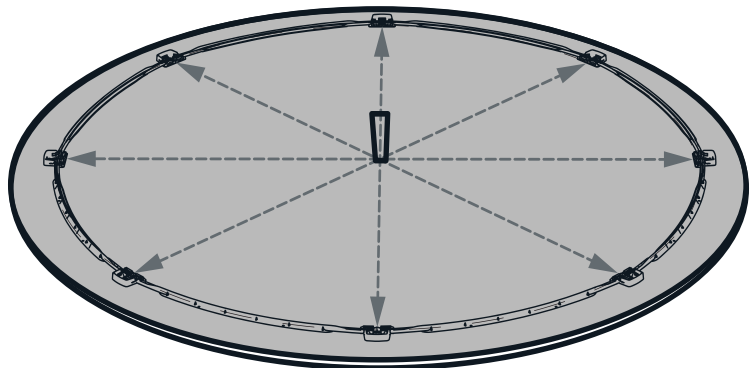

Measure each side of the foot the inside of the rail groove.

## INSTALLATION OF CONCRETE BLOCKS (OPTIONAL)

### STEP 1

For a more solid base under the feet, install solid concrete blocks underneath them. To do this, mark the location of the feet and remove the foot/rail assembly. The blocks should be sunk into the ground so that their upper face is at the same height as the surface of the aggregate already spread and compacted. All blocks must be flush with the ground, firmly wedged into the soil and level with each other.

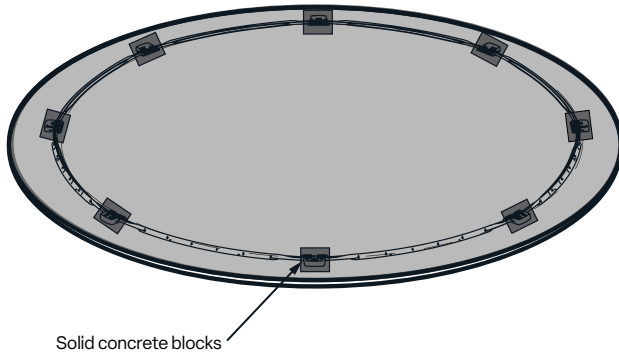

### STEP 2

Reposition the feet and rails and re-measure as described in steps 11 and 12 (in section "THE FOUNDATION").

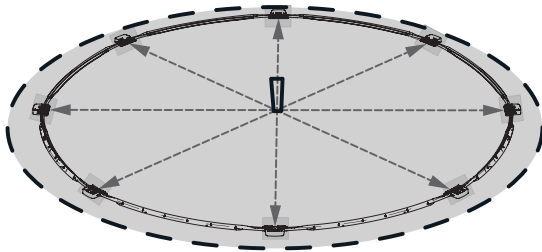

Measure the radius from the center of the pool to the inside of the rail on either side of the feet, then revalidate the diameter between each opposite foot.

## WALL INSTALLATION



**ANGER**

Do not install the wall in windy or stormy weather. Wait for a calm day. At least 3 people are required to install the wall. This may result in a risk of serious injury and/or material damage.

### STEP 1

Before you start installing the wall, make sure you have the following items within the circle of the pool rails: two sheets of plywood, some extra aggregate to make a cove and a stepladder to be able to climb out of the enclosure formed by the assembled pool wall.

### STEP 2

Note that the skimmer and water inlet are located at the beginning of the rolled-up wall, so position the roll to start unrolling the pool wall where you want to position these items.

### STEP 3

Position the 2 sheets of plywood inside the pool circle near where you want to position your pump and filter. Remove the wall from its box and place it on a sheet of plywood.

### STEP 4

Start unrolling the wall by inserting the bottom of the wall into the bottom rail (already positioned). The beginning of the wall should be in the center of a connecting foot to hide the closure behind an upright. Use the plywood sheets so that the wall doesn't touch the ground.



**ARNING**

Do not put sand inside the bottom rail, as this would make it difficult to insert the wall into it. It is mandatory to clean the inside of the rails to facilitate the insertion of the wall into them.

### STEP 5

We suggest installing the top rails on top of the wall as it is unrolled, to give the wall greater

stability and rigidity. It's important to support the top of the wall from the outside until it's fully installed in the bottom rail and closed. Support it by securing the top of the sheet with vinyl-coated hooks attached to a rope and staked into the ground with tent pegs.

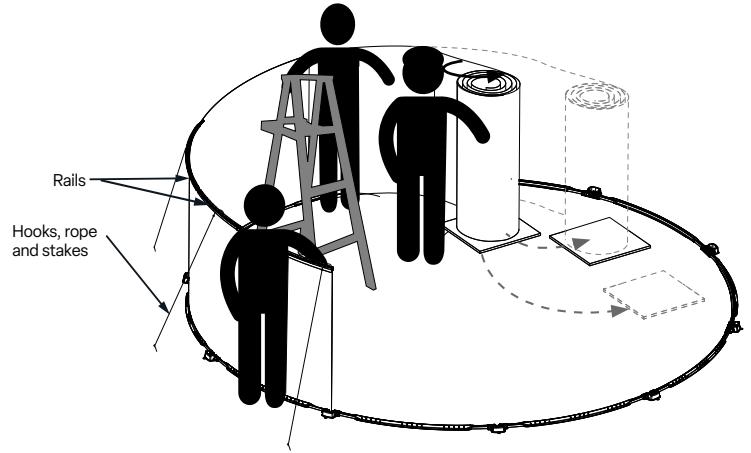

## BASIN ASSEMBLY

Once the wall has been completely unrolled and inserted into the bottom rails, 3 situations may occur:

- Wall looks too long (it is not). See step 1.
- Wall appears too short (it is not). See step 2.
- The assembly holes at both ends of the wall line up perfectly. Proceed to step 3.

### STEP 1

If your wall seems too long, the spacing between the rails in the feet needs to be enlarged. Gently tap the inside of the feet outwards, so that the pool's circumference expands slightly. If the wall overlap is long, you'll need to spread the expansion of the pool over several connections feet.

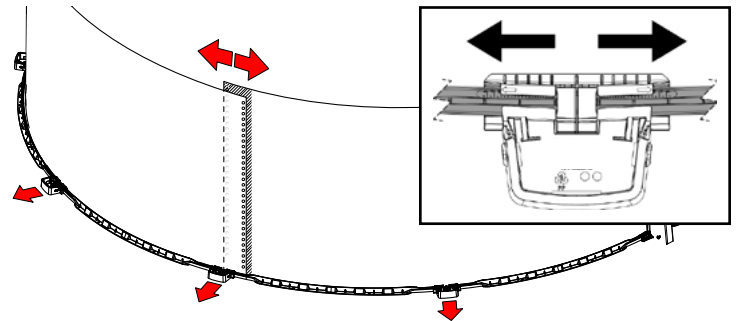

### STEP 2

If your wall seems too short, the spacing between the rails in the feet needs to be narrowed. Gently tap the outside of the feet inwards to reduce the pool's circumference slightly. If the wall overlap is short, you'll need to spread the expansion of the pool over several connections feet.

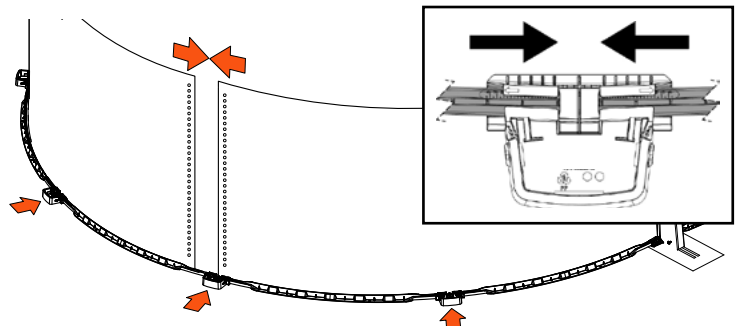

**If you have carried out one of the two steps (1 & 2), you must double-check the spacing between the rails in each foot to ensure that the spacing is equal on both sides of the center of the foot.**

**STEP 3**

Once the holes at the 2 ends of the wall are aligned (or very close to it), you can assemble them. To do this, place the two ends of the wall one on top of the other, **then add a wall bracket on each side of the wall (inside and outside).**

To help you align the holes, use a punch to pass through the holes so that they align correctly. Then install the screws (interior) and nuts (exterior), but don't tighten them just yet. It's best to put a screw at the bottom, middle and top to facilitate assembly.

**Make sure all holes have screws and nuts. Once all screws and nuts are in place, tighten them to a torque of 8.5 N-m (75 Lbf-in).**

Tighten the screws one by one as you go up and down, without forgetting any, which could cause long-term problems.

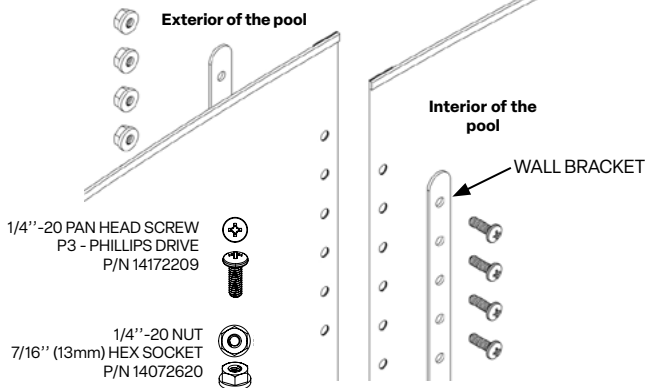
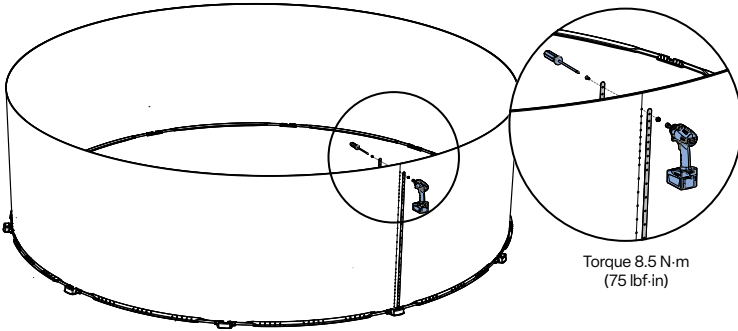
**WARNING**

Screw heads must be inside the pool. Set a torque wrench to 8.5 N-m (75 Lbf-in).

**STEP 4**

Cover the inside wall joint and screw heads with 2" (50mm) wide Duct Tape. Overlap 3 layers of tape to ensure that the liner is well protected from the sharp corners of the screws, and that the curvature of the liner at this position is softened.

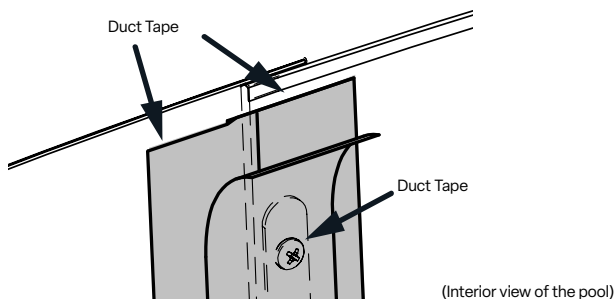
**STEP 5**

Once the wall has been assembled, check that the pool is still round. To do this, check the diameter of the pool in several places; each dimension should be identical. If this is not the case, adjust by pushing the feet inwards or outwards, as appropriate, to obtain a perfectly round pool.

**WARNING**

The pool must be level throughout its entire perimeter. A pool that isn't level throughout can be dangerous and collapse.

Once the wall has been installed, check the position of all the rails in each foot. Each rail must be positioned so that the gaps are equal at the center of the connecting foot. **Example below:** the space is equal between the end of the two rails and the center of the foot. You can refer to the gradation on the rail to ensure that the figure is equal on both sides.

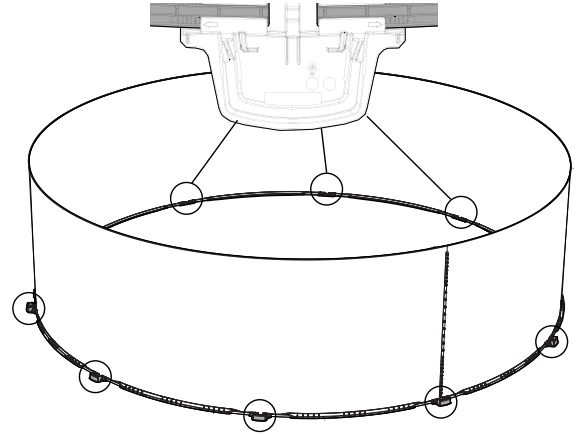
**WARNING**

**The cove is not optional; it must be fabricated in accordance with the specifications outlined in this manual in order to meet certification and compliance requirements.**

**BUILDING THE COVE**

The cove plays several important roles: it smooths the transition between the pool wall and the bottom, and it prevents the liner from being pinched or damaged under the bottom rails due to water pressure.

**STEP 1**

Place a polyethylene plastic film (such as a vapor barrier) all around the interior perimeter of the pool and secure it with duct tape. This layer helps protect the wall from possible contaminants found in the aggregate materials used for the cove.

**STEP 2**

Using rock dust or compaction sand, build a triangular-shaped cove at the base of the pool wall. The cove should be between 3" and 6" (7.5 cm to 15 cm) in height and extend 8" to 12" (20 cm to 30 cm) from the wall into the pool.

**STEP 3**

Once the cove is shaped, spread the aggregate evenly, moisten it, and compact it firmly around the interior of the pool—including the cove area—starting from the center and working outward in a circular motion (see page 6). Ensure the entire base is level and flat.

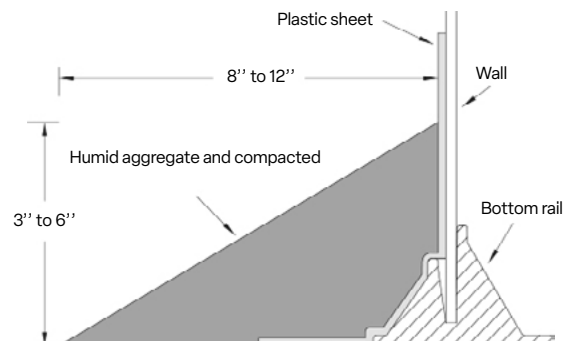

# INSTALLATION OF THE GEOTEXTILE MAT

## ⚠️ WARNING

Use a quality 100% synthetic needle-punched geotextile mat designed for this purpose. Never install the liner directly on the rock dust.

### ÉTAPE 1

Roll out the pre-cut geotextile mat to the size of the pool.

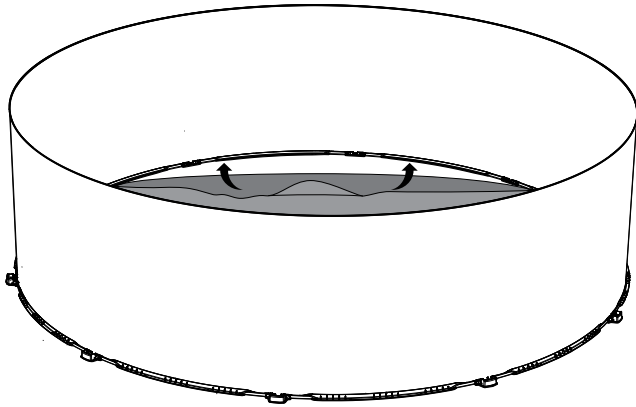

### STEP 2

Water the geotextile mat generously to spread it out and hold it in place.

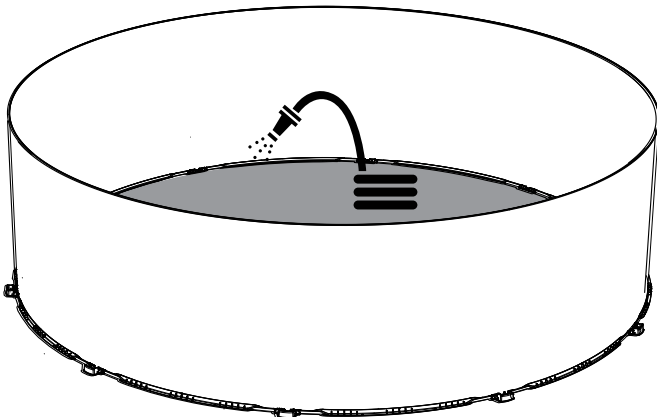

### STEP 3

Once wet, using the broom, place the fabric from the center outwards, sweeping to remove wrinkles.

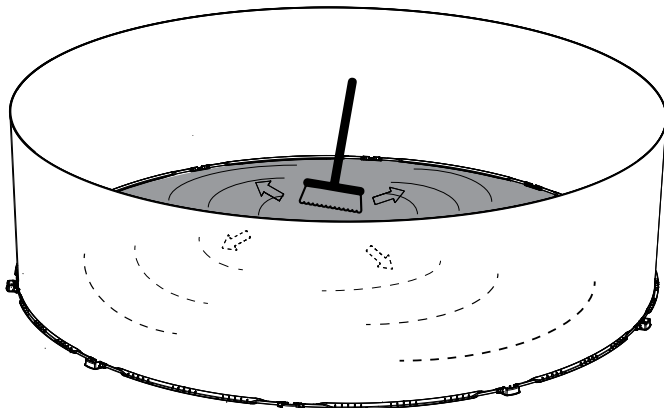

# STRUCTURE ASSEMBLY (GENERAL)

## INSTALLING THE UPRIGHTS

**Before installing the uprights, check that the rails are correctly centered in the connection feet. Adjust if necessary.**

### STEP 1

Insert the uprights into the feet. Push the upright down until you hear a click.

### STEP 2

There are spaces on each side of the connecting feet for installing screws. Installation of these screws is mandatory to make the assembly even stronger against freeze-thaw ground movement. These screws are mandatory in order to preserve the warranty.

**Do not install these screws immediately. Wait until the ledges have been installed before installing these screws.**

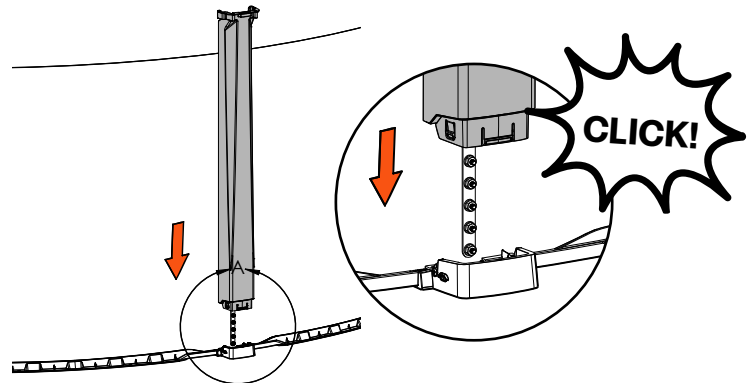

# LINER INSTALLATION (GENERAL)

REFER TO THE LINER MANUFACTURER'S INSTRUCTIONS BEFORE PERFORMING THIS STEP.

The canvas is generally smaller than the structure. We recommend laying the liner in the sun one or two hours before installation to allow it to warm up. It will stretch better under these conditions.

**Choose a liner that meets APSP-4 liner performance criteria. Do not install the liner on a cold, sunless day (16°C minimum). Avoid using very cold water to fill up the pool.**

The SUNLAB™ pool must be installed with a "U/J-Hook" or "Overlap" type cover.

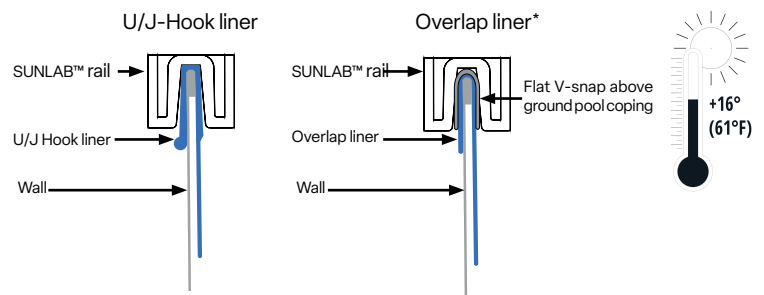

\* When installing an "Overlap" type liner, you'll need flat "V"-shaped coping to clamp the liner under the top rails. (in quantities equal to the top rails). Consult your dealer.

### ÉTAPE 1

Open the liner box.

## ⚠️ WARNING

Do not use sharp objects to open the box. This may damage the liner.

**STEP 2**

Take the canvas out into the sun unroll it to let it warm up.

**STEP 3**

Inspect the liner, joints and surface for holes.

**WARNING**

To avoid damaging the liner, remove your shoes when walking on it.

**STEP 4**

Lay the liner in the pool with the patterns facing upwards. The liner seam that runs around the bottom of the pool should be centered with the pool. The other seams should form parallel straight lines.

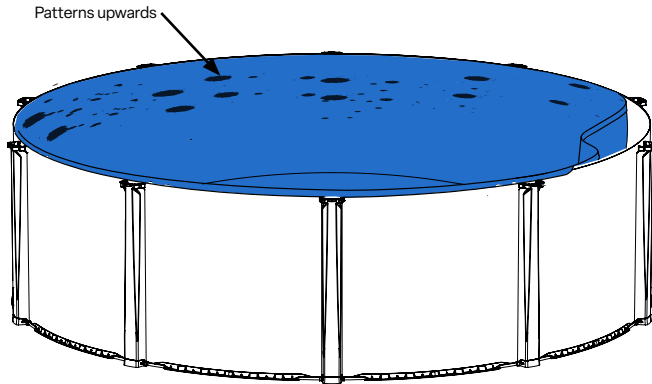
**STEP 5**

Stretch the liner to remove as many creases as possible from the bottom of the pool.

## ASSEMBLING THE LINER TO THE POOL WALL

### FOR INSTALLATION WITH HOOKED POOL LINER (U/J HOOK)

**STEP 1**

The top side of the canvas has a vinyl fold where there is no pattern. Open this fold with your fingers and hang it on the top of the wall.

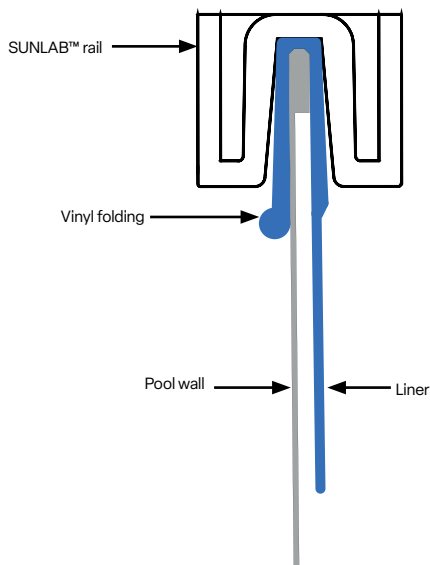
**STEP 2**

Do this all the way around the pool. The liner should not have any wrinkles, even in the portion running up the walls. If it does, adjust the liner either by turning the bottom, or by adjusting the installation of the fold around the wall.

## SERIES 5 ASSEMBLY

### INSTALLING THE TOP RAILS

As you install the liner fold, assemble the top rails to secure the assembly. Position the top rails so that they line up with the bottom rails, since the uprights will have to reach the junction of the rails (top and bottom).

Insert the liner into the slot and press along the rail from right to left.

Use a rubber mallet to tap the top rails gently into place, trapping the canvas in the rail.

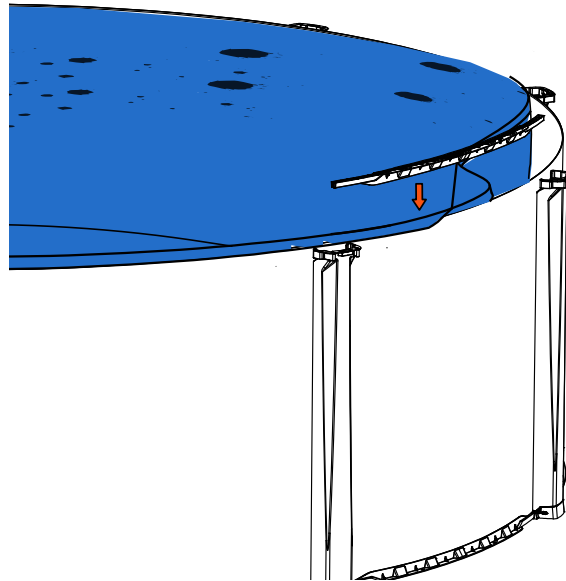

### INSTALLING THE TOP PLATES

**STEP 1**

From the outside, tilt the top plate so that the inner part hooks onto the top rail. Lower the plate, then slide it onto the upright, and press down.

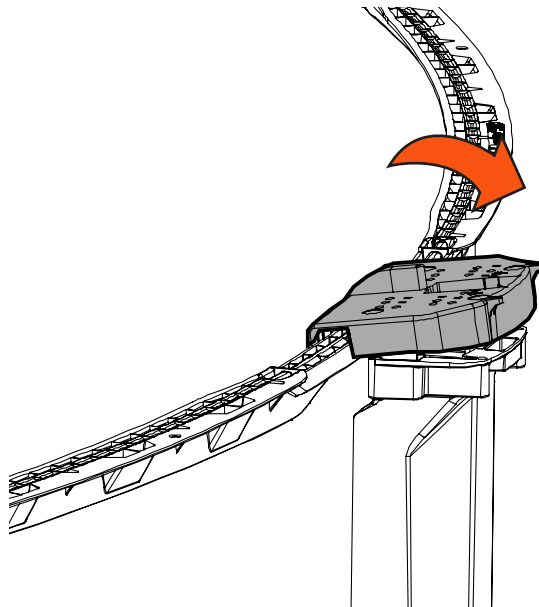

## SERIE 5 ASSEMBLY

### ASSEMBLING THE TOP PLATE (CONTINUED)

#### STEP 2

Make sure the holes in the top plate line up with those in the uprights. Install the 4 self-drilling screws (14455032) to assemble the top plate to the upright.

P/N. 14455032  
SCREW AT LOW SPEED  
Max torque 4 N·m (35 lb·in)

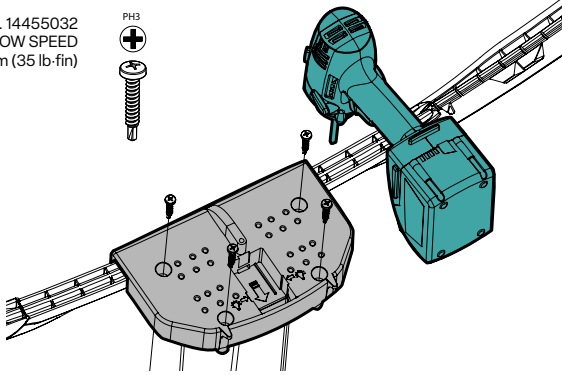

### INSTALLING THE LEDGES

#### STEP 1

Position all ledges on the pool structure.

#### STEP 2

Center the ledges between the top plates and the uprights.

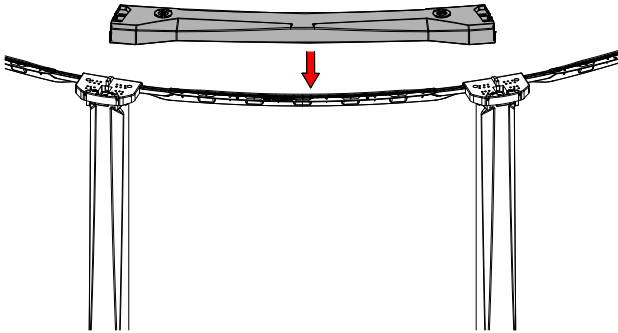

**Make sure the oblong holes on the ledge are aligned with the screw holes on the top plate.**

**Use the corrugation (folds or wrinkles) of the wall to check the verticality of the uprights.**

**Make sure the uprights are straight before screwing the ledges in place.**

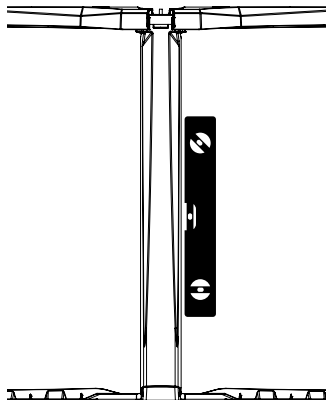

#### STEP 3

#### LEDGES POSITIONING

Push the ledge towards the outside of the pool until the edge touches the top plate.

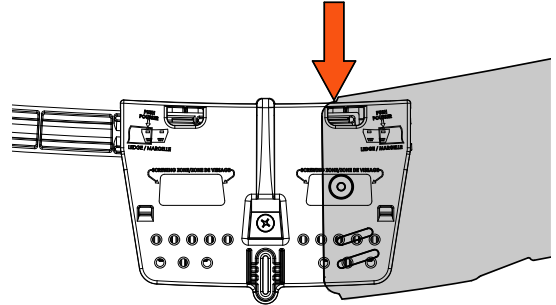

#### STEP 4

#### FIXING OF LEDGES

Screw on the ledge using 2 self-tapping screws on each side (14455110) (total of 4 per ledges). Use the oblong holes as far out as possible to screw the ledge. Several holes are available on the top plate to make the assembly. You can use the one that seems best located for your assembly.

P/N 14455110  
SCREW AT LOW SPEED  
Max torque 4 N·m (35 lbf·in)

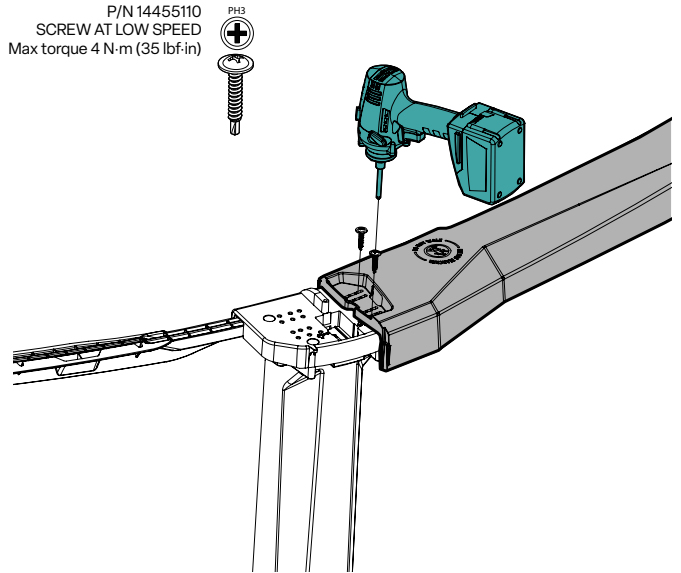

## SERIE 5 ASSEMBLY

### INSTALLING THE LEDGE COVERS

#### STEP 1

Pre-assemble the front and rear ledge cover by inserting them into each other in the detail provided, until they click into place.

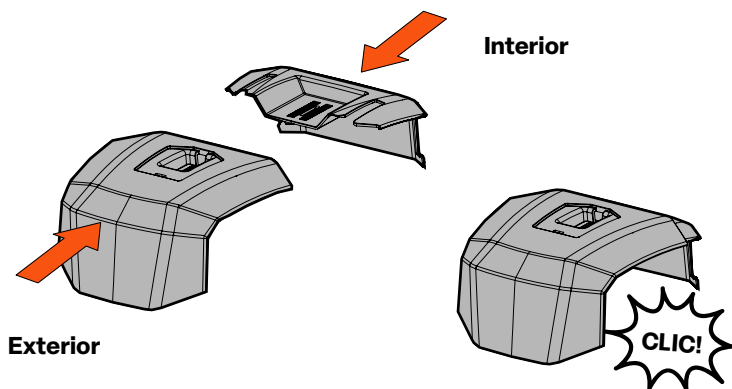

#### STEP 2

Insert the rear hook of the assembled covers under the inner edge of the ledge, then rotate it towards the outside of the pool, lowering it.

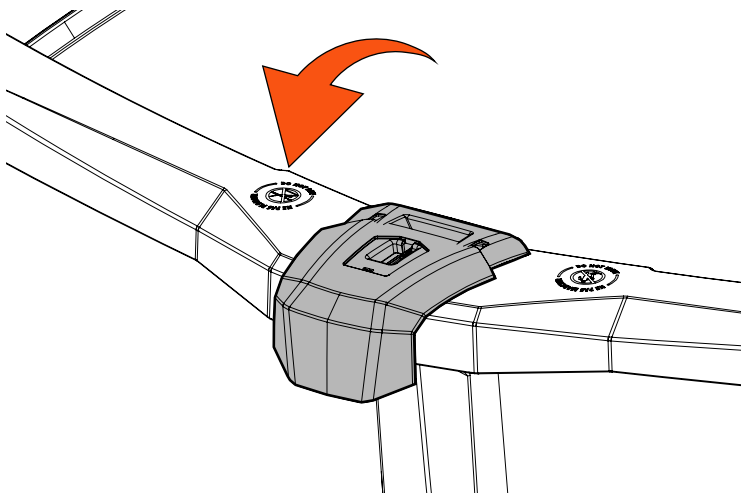

#### STEP 3

Hold the rear of the ledge cover and push on the front until they are firmly in place.

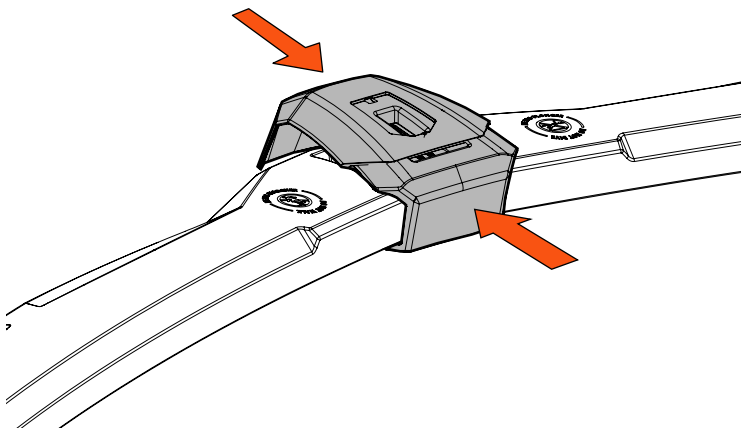

#### STEP 4

Align the top slot in the cover with the central hole in the top plate. Screw the assembly in place using a 14455032 screw.

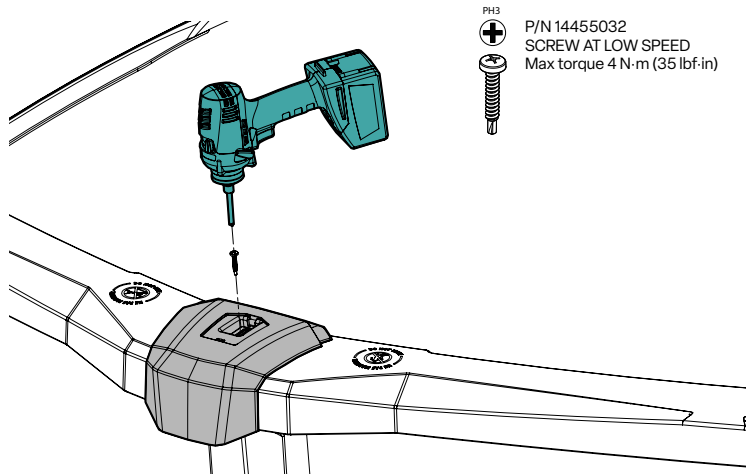

#### STEP 5

Install the ledge cover cap by pushing it until it clicks into place.

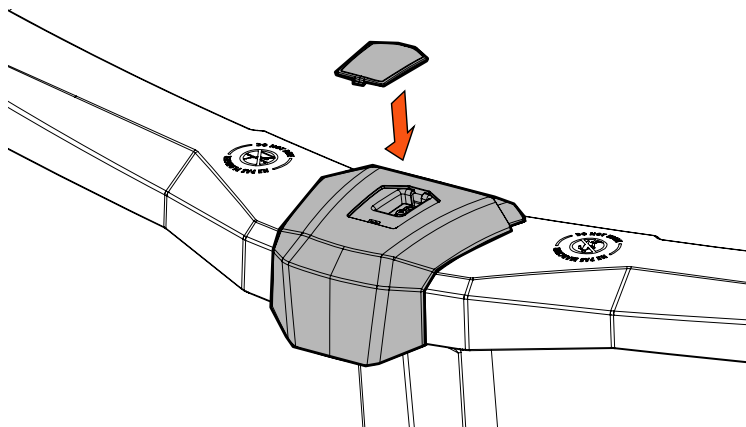

## SERIES 3 ASSEMBLY

### INSTALLING THE FIRST TOP RAIL

- Center the hook-shaped symbol with the center of the top plate.
- Press all the way along the rail from the right-hand end to the left to secure the liner.

Use a rubber mallet to tap the top rails gently into place, trapping the liner in the rail.

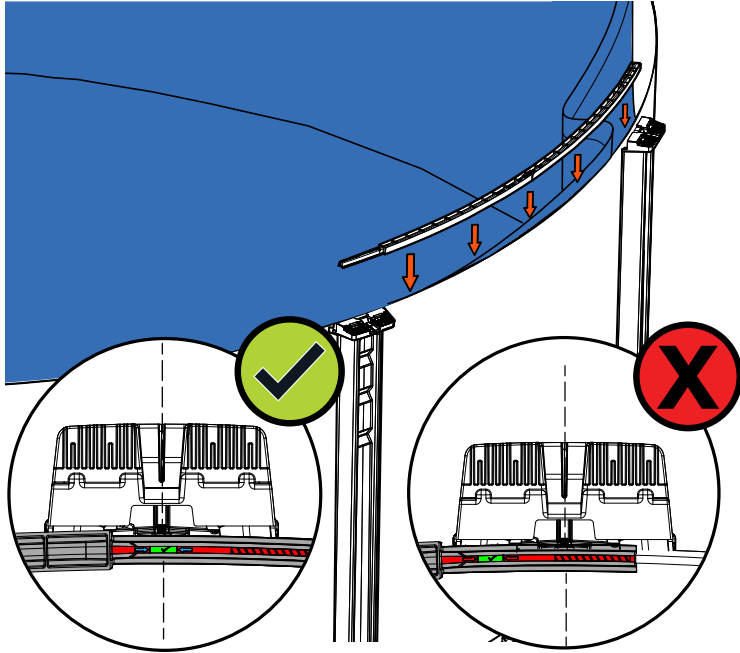

### INSTALLATION OF SUBSEQUENT RAILS

- Subsequent rails are installed in a clockwise direction.
- Align the female end of the second rail with the hook-shaped symbol on the first rail or in the adjustment area.
- Press the entire length of the rail from the right end to the left to secure the liner.

Use a rubber mallet to tap the top rails gently into place, trapping the liner in the rail.

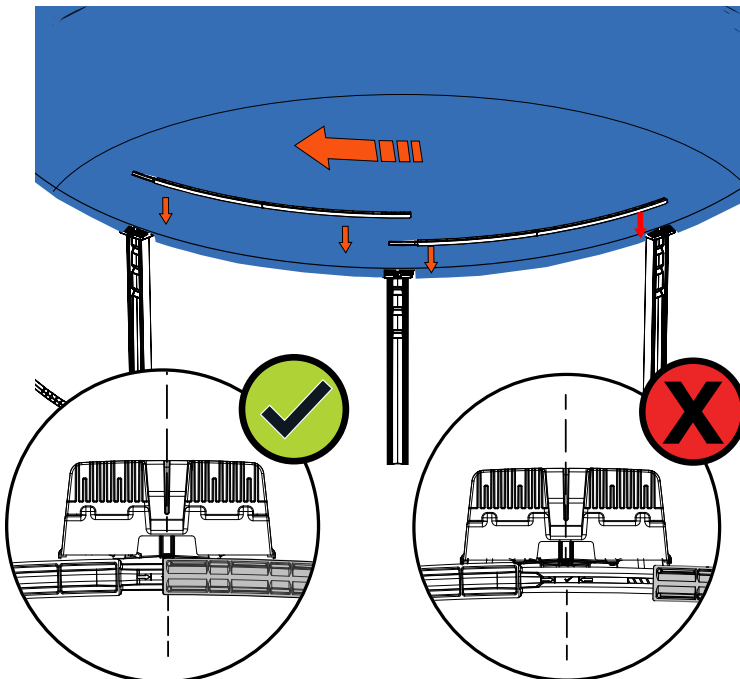

### INSTALLING THE TOP PLATES

#### STEP 1

From the outside of the pool, tilt the support towards you so that the inner part hooks onto the rail.

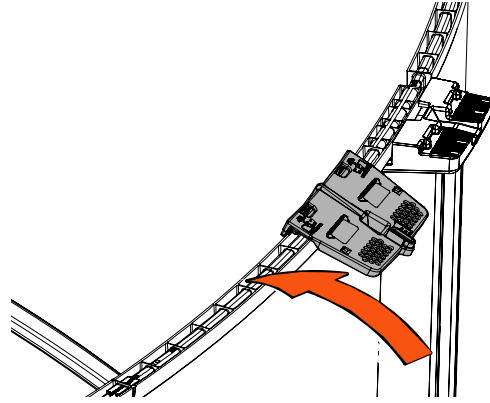

#### STEP 2

Lower the top plate, then slide it over the upright and press down. You'll feel the plate fall into place.

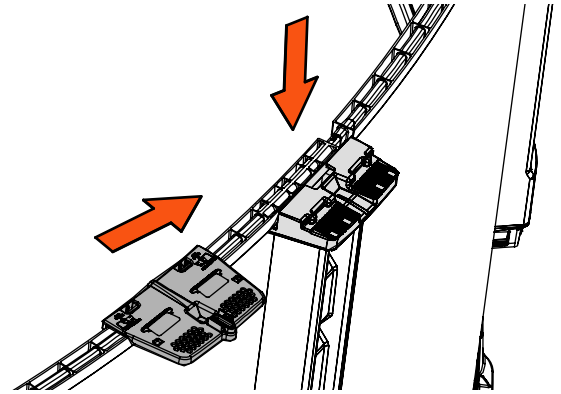

#### STEP 3

Make sure the hole in the top plate lines up with the hole in the upright. Install a self-drilling screw (14455032) to secure the top plate to the upright.

NO. 14455032 PH3  
SCREW AT LOW SPEED  
Couple max. 4 N·m (35 lbf·in)

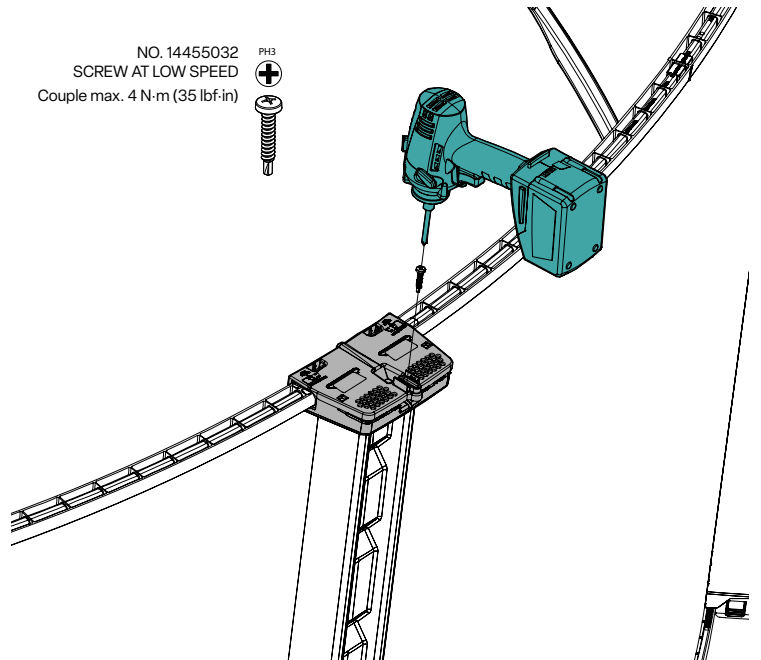

## SERIES 3 ASSEMBLY

### INSTALLING THE LEDGES

#### STEP 1

Centre the ledges between the top plates and the uprights.

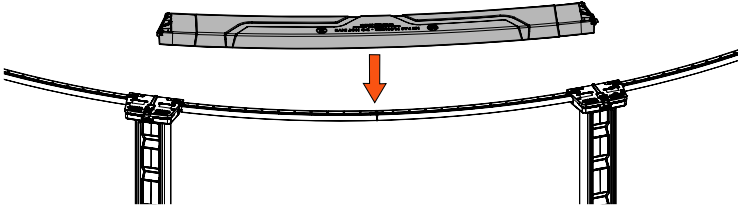

#### STEP 2

Before screwing, pull the ledge towards the outside of the pool so that the inside corner of the coping is flush with the inside face of the top plate. **Make sure that the round hole is in the screwing area on the bracket.**

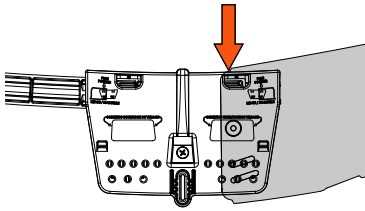

Use the corrugation (folds or wrinkles) in the sheet to check that the uprights are vertical. Make sure the uprights are straight before screwing the ledges in place.

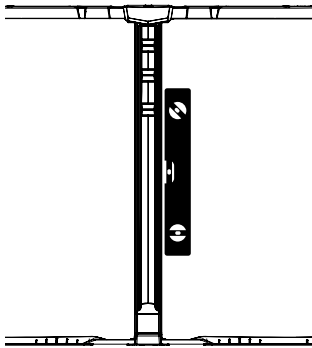

#### STEP 3

Screw on the ledge using 2 self-tapping screws on each side (14455110) (total of 4 per ledge). Use the oblong holes as far out as possible to screw the ledge.

Several holes are available on the top plate to make the assembly. You can use the one that seems best located for your assembly.

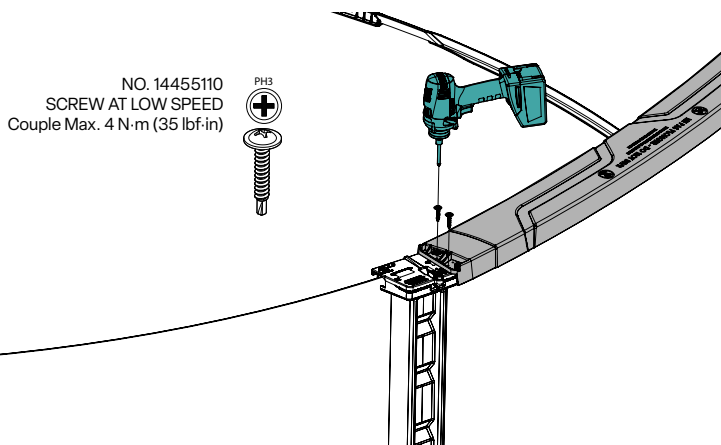

### INSTALLING THE LEDGE COVERS

#### STEP 1

Hang the cover on the lower edge of the ledge inside the pool.

#### STEP 2

Rotate the cover so that it rests correctly on the top of the ledge.

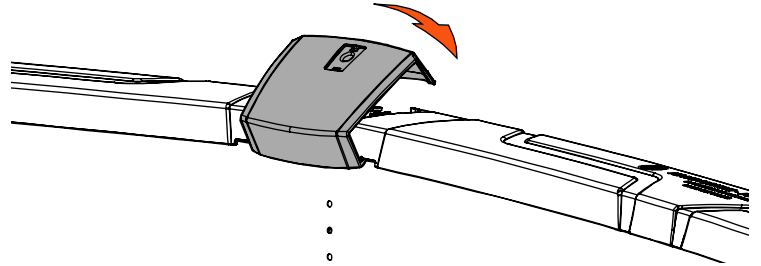

#### STEP 3

Pull the ledge cover towards the outside of the pool. Align the screw hole in the cover with the space provided in the top plate. Screw on the ledge cover using 1 screw (14455032).

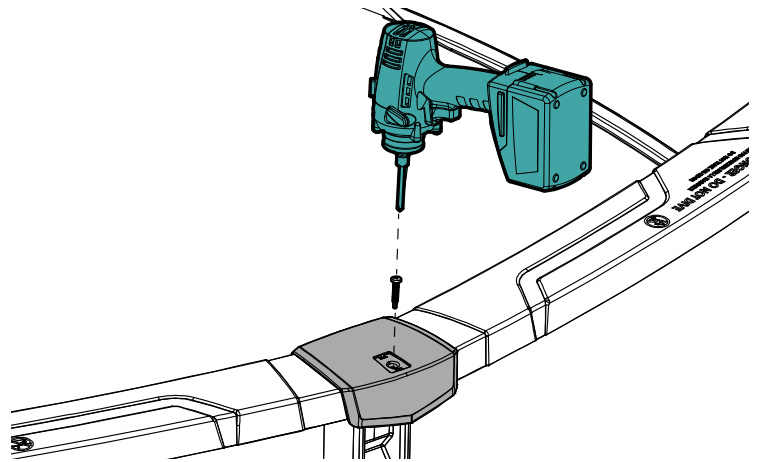

#### STEP 4

Install the ledge cover caps by pushing them into place until they are fully inserted.

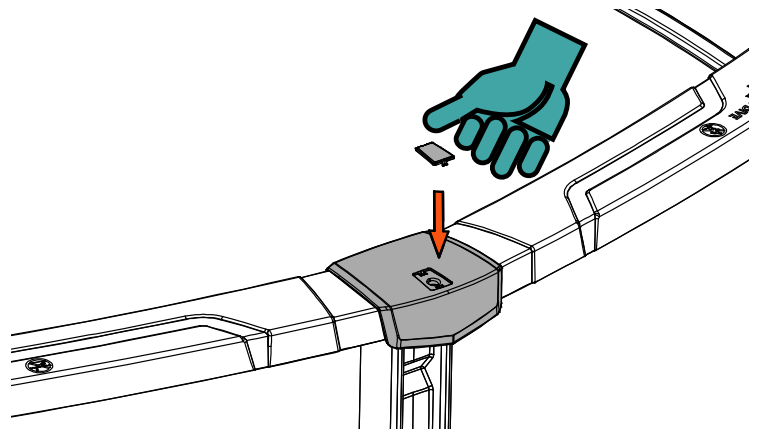

#### STEP 5

Install the safety labels as indicated in the WARNING section on page 17 and 18 of this manual.

## FOR ALL SERIES

## FIXING BOTTOM PLATES TO THE STRUCTURE

Fix 2 screws (14455032) in the rear detail on each side of the bottom plate to secure the entire structure. These fasteners will prevent the uprights and bottom plates from slipping out of place when the ground freezes and thaws.

**WARNING**

The presence of hardware in the bottom plate is mandatory. They provide strength and stability when there are ground movements.

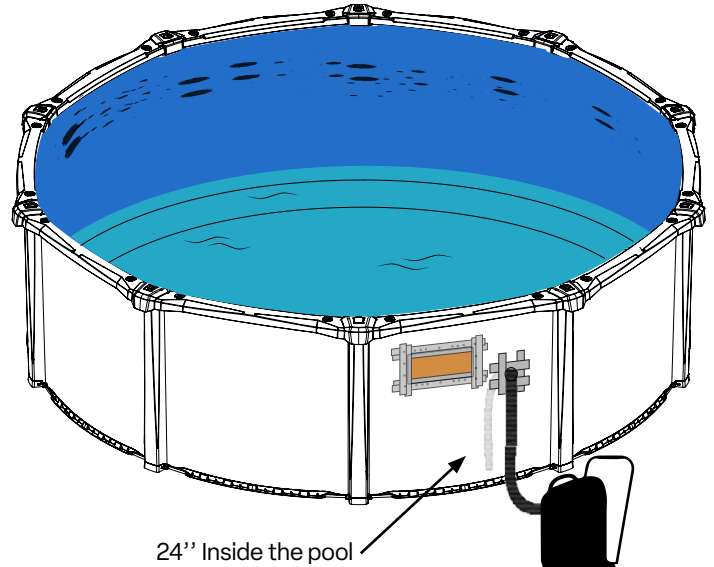
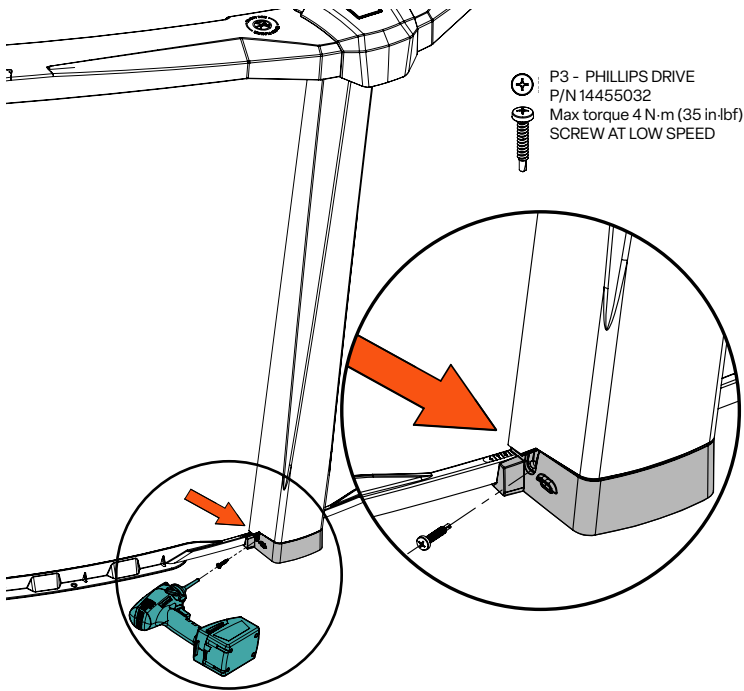

## FILLING THE POOL

## STEP 1

A vacuum cleaner is used to remove the air between the liner and the pool wall. By removing the air, the liner will stretch and stick to the walls of the pool. This operation will allow you to correct the surface of the liner to remove wrinkles.

**WARNING**

Do not use an industrial vacuum cleaner of more than 5 HP, which could suck up the liner and damage it, or even puncture it.

**WARNING**

Make sure that the end of the vacuum hose has no sharp edges that could damage the liner. Tape the edges of the nozzle if in doubt.

## STEP 2

On the outside wall of the pool, seal the skimmer hole with a piece of cardboard and tape around the edge with grey "Duct Tape". Make sure you cover the rectangular section and the holes so that no air can seep through.

Insert the vacuum cleaner hose about 24" (60cm) into the water inlet hole from the outside. Make sure the hose is at least 6" (15cm) away from the cove to avoid moving it or suctioning it.

Fix and seal the vacuum hose to the outside of the pool wall using grey "Duct Tape". Be sure to seal the hose and the hole to prevent air from seeping in.

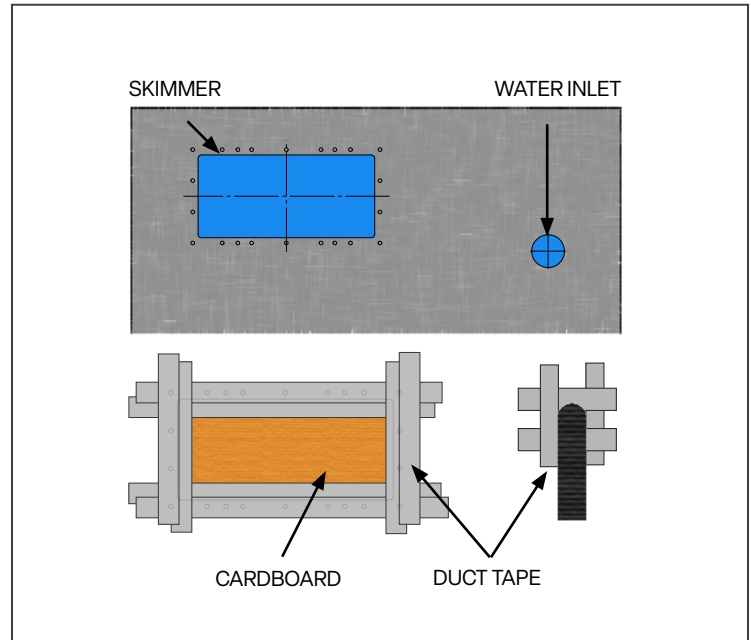

## STEP 3

Start the vacuum cleaner. The liner will begin to stick to the walls. If there are any creases, it's time to stretch the liner to remove them.

## STEP 4

When you see that the liner is no longer moving under suction and there are no creases, start filling the pool with a hose while leaving the hoover running.

**Throughout the filling process:**

- **Check the liner for creases.** To prevent the liner from moving, smooth out any creases visible at the bottom of the pool before there is too much water in the pool. The slow flow of the hose will allow the liner to stretch and give you time to put it back in place if you see any creases.

- **Inspect the structure regularly.** Make sure the bottom rails stay in place and flat against the foundation. Make sure the wall stays in place in the rails and that no folds form in the wall when the weight of the water pulls on the liner. If the metal wall bends, stop filling immediately, examine and correct the problem with the structure.

## STEP 5

When there is about 12" (30 cm) of water from the bottom of the pool, stop the vacuum cleaner, remove the hose from the water inlet hole and the cardboard from the skimmer.

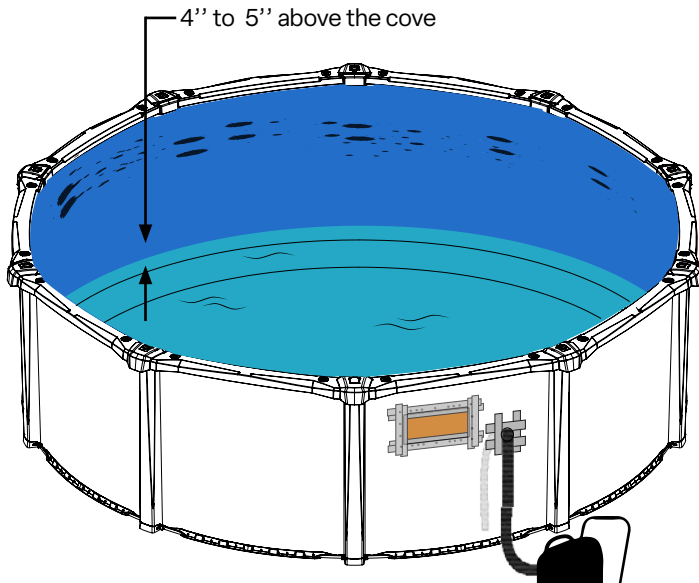

**STEP 6**

When the water reaches a level of 12" (30 cm) from the bottom, you can use a faster water flow.

**WARNING**

To allow the pool to expand naturally, the flow rate when filling must not exceed 16 GPM. Do not make the foundation drain protection around the pool until it is completely filled with water.

**STEP 7**

When the water reaches a level of 24" (60 cm) from the bottom, the liner has stretched correctly. It's time to install the skimmer and water inlet. Follow the manufacturers' instructions for the installation of these accessories. It is very important to be meticulous when performing the installation of the skimmer and water inlet, as they could leak and corrode your pool wall.

**WARNING**

A basic circulation and filtration system **MUST BE INSTALLED** on your pool.

**STEP 8**

The basic filtration system includes, as a minimum, in the order of installation:

- A skimmer
- A recirculation pump
- A filter
- A water inlet

Be sure to use and properly maintain the equipment in accordance with the recommendations of their respective manufacturers. Do not switch on the equipment at this stage. If the water level reaches 2" below the inlet hole and the above equipment is not installed, stop filling the pool and install your equipment.

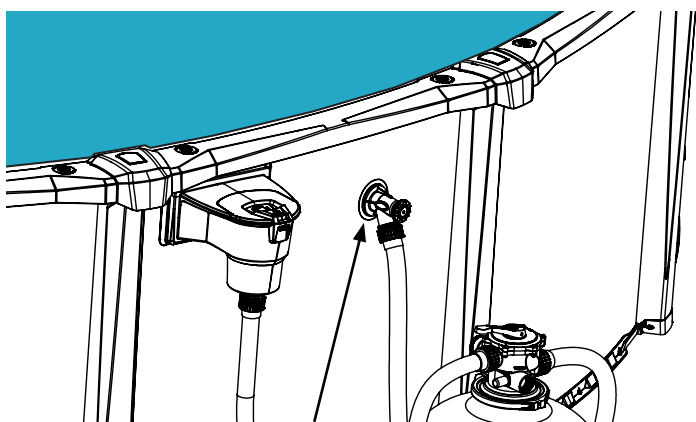

2" minimum below the inlet hole

**WARNING**

Make sure you comply with all local and provincial (State) regulations when installing pool accessories. Elements allowing entry to the pool must be approved for user safety.

**STEP 9**

Once your filtration system is installed, fill the pool until the water reaches 1.5" to 2" from the top of the skimmer or until it reaches the 'Maximum' mark on the decorative plate of the CARVIN® skimmer.

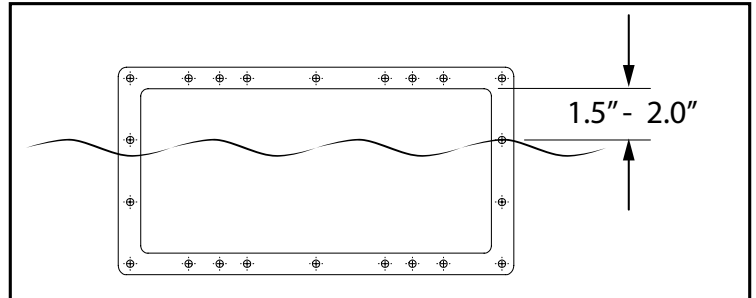

**STEP 10**

You can now switch on your circulation and filtration system. Make sure you use and maintain this equipment in accordance with the recommendations of their respective manufacturers.

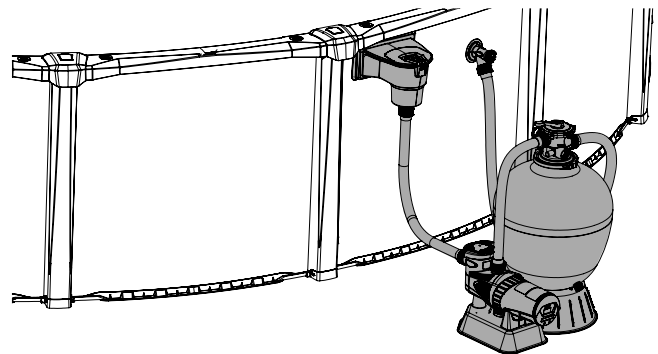

**WARNING**

Never introduce chemicals into the pool through the skimmer. This will cause major problems for your filtration system and could damage it in the long term.

**INSTALLING SAFETY STICKERS**

Before using your pool, the first step is to affix the safety stickers. It is **STRICTLY FORBIDDEN** to remove these stickers. If the stickers supplied are not affixed and visible around your pool, you could be prosecuted in the event of an accident. Follow the information on the following pages to put them in the right place. **You must not use your pool if the stickers are not affixed.**

**WARNING**

**OWNERS AND INSTALLERS.** Fit the warning stickers supplied, as shown in this manual. These stickers alert users to the dangers of jumping and diving and can prevent accidents.

**INTERIOR STICKER**

Place the small warning stickers on the liner above the water level and on the ledge opposite to the ladder so that they are visible to swimmers.

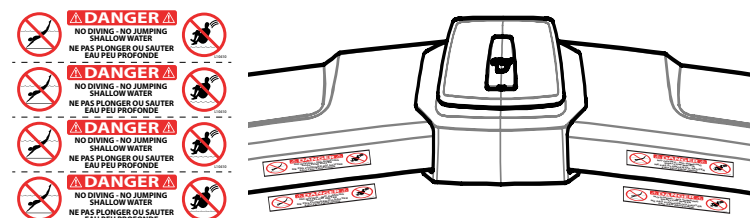

## ENTRY STICKER

Install the large warning sticker on the wall at the entrance to the pool to ensure that everyone entering the pool is aware of the dangers.

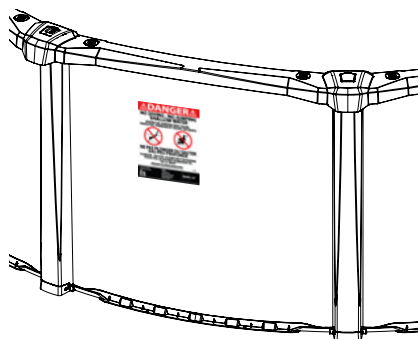

## FOUNDATION DRAINAGE PROTECTION

To protect the compacted foundation and prevent it from being drained, spread river rock or stone a minimum of 3/4" diameter all around your pool. A strip at least 10" wide and 2 to 3 inches thick. The top of the lower rails must remain visible.



### WARNING

Not doing this or using any other organic product such as soil, peat moss, turf, mulch or any other moisture-retaining substrate will accelerate the deterioration of the pool's components.

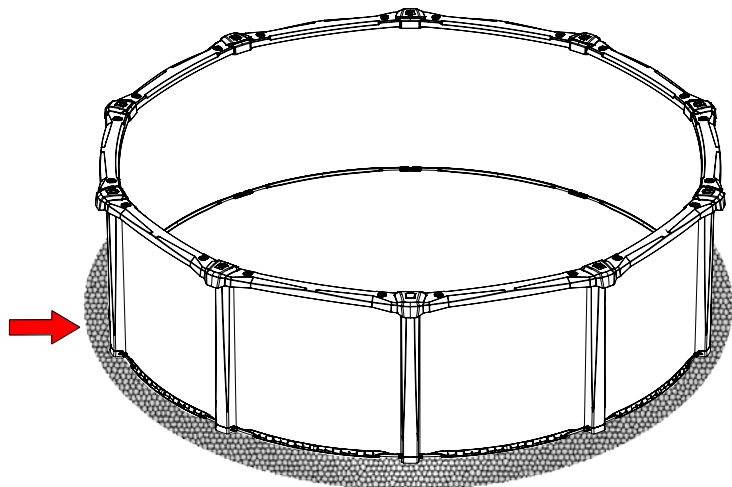

## INSPECTION

The parts most likely to cause a problem with leaks are the skimmer and the water inlet. Regularly inspect the area around these two components to check that no water is leaking onto the pool wall. Carry out the necessary repairs to the skimmer and water inlet joints (or replace them) in order to stop these leakages, as they can cause corrosion and seriously damage the pool's sheet metal wall, causing it to eventually burst. This could cause serious damage to your property, that of your neighbors and put lives in danger.

Your pool liner should be inspected regularly for leaks. Water leaks can damage the wall of your pool, as the water contains corrosive products that will accelerate corrosion. If you detect leaks, ACTION MUST BE TAKEN IMMEDIATELY. You can easily repair minor liner damage using a patch kit available from your retailer.



### WARNING

Failure to carry out these inspections and repairs will invalidate the manufacturer's warranty.

## WATER CHEMISTRY

Water chemistry plays an essential role in the good functioning of a swimming pool. Clean, balanced water is essential for the safety and well-being of pool users, as it can cause illness and infections. Unbalanced water will also lead to premature deterioration of pool components and equipment. That's why it needs to be assessed on a regular basis. A number of products are available to help you assess, treat and rebalance your water. For an assessment and advice on the quality and treatment of your water, visit your retailer with a water sample. See the table below for the values for balanced pool water.

It's important to remember that the filtration system and proper circulation of the water in the pool account for more than 50% of healthy water maintenance. It's therefore important to ensure that the water circulates well around the pool and to maintain the filtration system regularly to improve sanitation and reduce algae growth and other bacteria.

TABLE - RECOMMENDED WATER CHEMISTRY PARAMETERS

Parameters	Minimum	Target	Maximum
<b>Temperature difference</b>	+59°F (15°C)	-	+104°F (+40°C)
<b>salt concentration (Olo™)</b>	3000 ppm	3300 ppm	4000 ppm
<b>Cyanuric acid</b>	30 ppm	30-50 ppm	100 ppm
<b>pH</b>	7.2	7.4 - 7.6	7.8
<b>Free chlorine</b>	1.0 ppm	2.0 - 3.0 ppm	3.0 ppm
<b>Combined chlorine (Chloramines)</b>	-	0 ppm	0.2 ppm
<b>Total alkalinity</b>	60 ppm	100-120 ppm	180 ppm
<b>Calcium hardness</b>	200 ppm	-	300 ppm
<b>Total dissolved solids (TDS) (including salt)</b>	-	-	1500 ppm
<b>Metals (copper, iron, manganese)</b>	-	NONE	-
<b>Nitrate</b>	-	NONE	-
<b>Phosphate</b>	-	NONE	-
<b>Saturation index</b>	-0.3	0.0 / +0.5	+0.5

- Sources: Health Canada publication H129-4/2011E & ANSI/APSP/ICC-4 2012

- ppm = particle per million, ppb = particle per billion

- This series of pools is compatible with a salt chlorine generator; consult the owner's manual Owner's Manual for ideal pool water salinity levels.



### WARNING

Pool water contains a number of products that are corrosive to the pool wall. It is important to check that there are no leaks in the liner. Any leaks will lead to long-term corrosion of the wall, which will reduce its strength. The wall could break and cause major damage to your property and/or your neighbors and could also cause serious injury to people near or in the pool.

## REGULAR CLEANING

Keep the walls and plastic structure clean. Always clean any chemical deposits that may appear on the pool's external surfaces. We recommend cleaning these surfaces (structure and walls) at least once a year with a degreasing cleaning product that does not contain bleach. It is important to clean the liner, where deposits can form when the water evaporates. It is also recommended that any algae deposits on walls or equipment immersed in water should be checked and cleaned regularly.

## WINTERIZING THE POOL

In regions where freezing temperatures occur, it is common practice to close an outdoor swimming pool during the winter. This is known as winterization. This step should be considered

as soon as the pool is installed. All our pools have been designed to remain assembled outside during the winter. However, the following instructions should be followed when winterizing your pool. Proper winterization should only take a few hours and will make spring opening much easier.

### WARNING

Failure to follow winterization instructions may cause irreparable damage to the pool and/or harm to your home or surrounding structures.

As the water temperature cools, there is less and less need to add chemicals. It is, however, necessary to check the water's chemical parameters periodically in order to keep the water clean and within the recommended values. Failure to comply with these values could cause the pool liner to tarnish and shorten its lifespan. We recommend winterizing your pool as late as possible (late September/early October) when the water is below 10°C (50°F). At this temperature, micro-organisms proliferate very slowly.

## INSPECTION

### STEP 1

Before closing the pool each year, check the water parameters (ph, alkalinity, chlorine, etc.) Water with unadjusted parameters will damage the liner and could cause corrosion on the pool wall.

### STEP 2

Check that there are no leaks in the liner. To be sure, for a week in early September, check that the water level does not drop. If the water level does drop, it means there is a leak. Immediately repair the holes in the liner using repair kits that can be purchased from your pool specialist. Check that there are no leaks around the skimmer or water return. If a leak is found around these elements, action must be taken immediately to rectify the situation. Check that the liner is still securely fastened to the top of the sheet metal wall.

### WARNING

Water leaking from the liner during the winter can cause significant soil movement when the water freezes under the pool. This can cause major damage to your pool.

### STEP 3

Check the structure of the pool for scratches and/or corrosion on the wall. If necessary, repair them using an anti-corrosion enameling product. Scrub the rusted surface with a wire brush, make sure all the rust is removed, apply the anti-corrosion product and paint the surface to match the color of the wall. Also check that the wall joint (joining the 2 ends of the pool wall) is solid and that the screws are tight.

## WATER PREPARATION

### STEP 1

Keep your pool water within acceptable parameters in the weeks leading up to its closure.

### STEP 2

Clean the bottom of your pool of any dirt before lowering the water level.

### STEP 3

Lower the water level to between 6" and 20" (15 cm and 50 cm) below the level of the water return, depending on the climate of your region. Check with your retailer for recommendations on the water level to maintain when winterizing.

**For regions where there is frost**, the pool must be emptied between 15" and 20" (40 cm and 50 cm) below the water inlet.

**Do not empty the pool completely.** This operation could cause your liner to move. It would also lighten your pool, which could be blown away in strong winds and cause major damage to your property or that of your neighbors. It could also cause serious injury or even death.

### STEP 4

Use a set of pool closure products available from your retailer. Using this kit will considerably reduce the time and quantity of chemicals required when you restart your pool each spring.

### WARNING

It is advisable to check the water level in the autumn after winterization before the water freezes. If the water level rises drastically, it is advisable to re-drain the water to bring it back down to the recommended level.

### WARNING

It is important never to lower the water in the pool if it has frozen and forms a block of ice, as this can cause considerable damage to the liner and the pool.

## WINTERIZING OF THE FILTRATION AND RECIRCULATION SYSTEM

### STEP 1

Disconnect all hoses from the filtration system: pump, filter, skimmer, valves, water return, etc.

### STEP 2

Drain the pump, filter and water heater and winterize them according to the recommendations in their respective manuals.

### STEP 3

The winterization of the water return and the skimmer is different according to the climate of the region in which you are located. Ask your retailer for recommendations.

**For regions where there is frost:** It is imperative never to obstruct the return water and skimmer openings. Make sure that the water entering the water return drains away from the pool at all times. Regularly check that the openings are not blocked by ice.

### STEP 4

If your pool is equipped with a bottom drain (**for regions where frost is present**), it is essential to use antifreeze specially designed for swimming pools to prevent the pipe from freezing and rupturing.

Make sure that the water level in the pool is correctly lowered, then remove the hose that connects your filtration system to your bottom drain. Make sure that the end of the hose is above the water level at all times (so that the pool does not drain through it). Empty the antifreeze slowly into the hose until you see it coming out of the bottom drain. Make sure the hose stays above the level of the water inlet throughout the winter by securing it to the ledge.

### STEP 5

Store all components; pump, ladder and any other product that needs to be stored in a well-tempered place protected from the elements.

### WARNING

Do not switch off the filtration system until the pool is completely closed, to keep the water healthy until it is winterized.

### WARNING

Closing the pool too late could allow the water in the pipes, skimmer and water inlet to freeze and damage the filtration system components and the pool.

## USING A WINTER COVER

When using a winterization cover for pools, we recommend using a mesh-type pool cover specially designed for winterizing above-ground pools. The mesh has a porous woven design that allows water to flow into the pool under the cover while trapping leaves and debris.

Opaque or waterproof polyethylene, plastic or vinyl tarpaulins are not recommended. These tarpaulins are generally used for camping and protecting objects from the rain. These covers allow water, snow and ice to accumulate on top, creating significant weight on the pool structure. This extra weight can cause the uprights to pull out or the walls of the pool and its structure to collapse.

To use a winter cover, we recommend that you ask your local pool specialist for information. As there are several types of winter cover available, the pool professional will be able to advise you on how to install one.

### WEIGHT FOR WINTER COVER

Some winter covers use a weight system to keep them in place during the cold season. It is important to use weights intended for this purpose as they are designed to protect the pool wall. The use of improvised weights for this purpose (plastic gallons filled with water attached by a rope or anything else) is forbidden as they can be blown away during periods of high winds and damage the pool wall.

**IMPORTANT**

Using a liner and attachment system other than those specifically designed for an above-ground pool can cause considerable damage. Check with your dealer.

**RECOMMENDATIONS AND MAINTENANCE DURING WINTER**

- 1- Check that there is no obstruction in the water inlet orifice and that the water can drain away from the pool.
- 2- Check that water, snow and ice do not accumulate in the skimmer during the freezing period. It is important to check regularly that these are free of build-up at all times. This could damage the skimmer and cause the pool wall to collapse when the thaw comes.
- 3- The pool is designed to support the volume of water contained in it, and therefore to work horizontally. Make sure you remove any snow that accumulates on the structure (the ledges). Do not allow more than 12" (30cm) of snow to accumulate on the pool ledges at any given time.
- 4- Do not hit a pool containing frozen water, as this will damage it.
- 5- Do not climb inside a frozen pool. This could cause the ice to shift and rub against the liner, breaking it and seriously damaging the pool.

**SPRING OPENING**

When the outside temperature reaches 10°C (50°F) and the pool water has completely thawed, it's time to restart your pool's filtration system.

**STEP 1**

Remove the winter cover from the pool, remove any water that may have accumulated on the cover over the winter and any other dirt and leaves.

**STEP 2**

Reposition your filtration system and reconnect the pipes linking it to the skimmer and the water inlet.

**STEP 3**

Fill the pool until the water level is in the middle of the skimmer.

**Inspect your pool for visible corrosion or leaks. Pay particular attention to the areas around the skimmer and the water inlet. If necessary, correct the problem immediately.**

**STEP 4**

Clean the bottom of the pool by vacuuming up any leaves or dirt. Put the sand filter in the "DRAIN" position to remove the dirt from the pool without going through the filter. This operation in "Drain" mode will extend the time before you need to "backwash" the sand in your filter.

Do not empty your pool completely to clean the water unless you have to, as this could cause creases in your liner. If you absolutely must, do not leave the pool empty for a long period. A liner exposed to the sun could shrink and dry out. The structure could also move in strong winds, making it very dangerous.

**STEP 5**

Adjust the chemical parameters of your pool water. Contact your pool professional for recommendations on adding chemicals to your pool water in spring.

Make sure that the skimmer and water inlet are not leaking. Such a leak could corrode the wall of the pool and seriously damage its structure.

Use only genuine SUNLAB™ replacement parts.

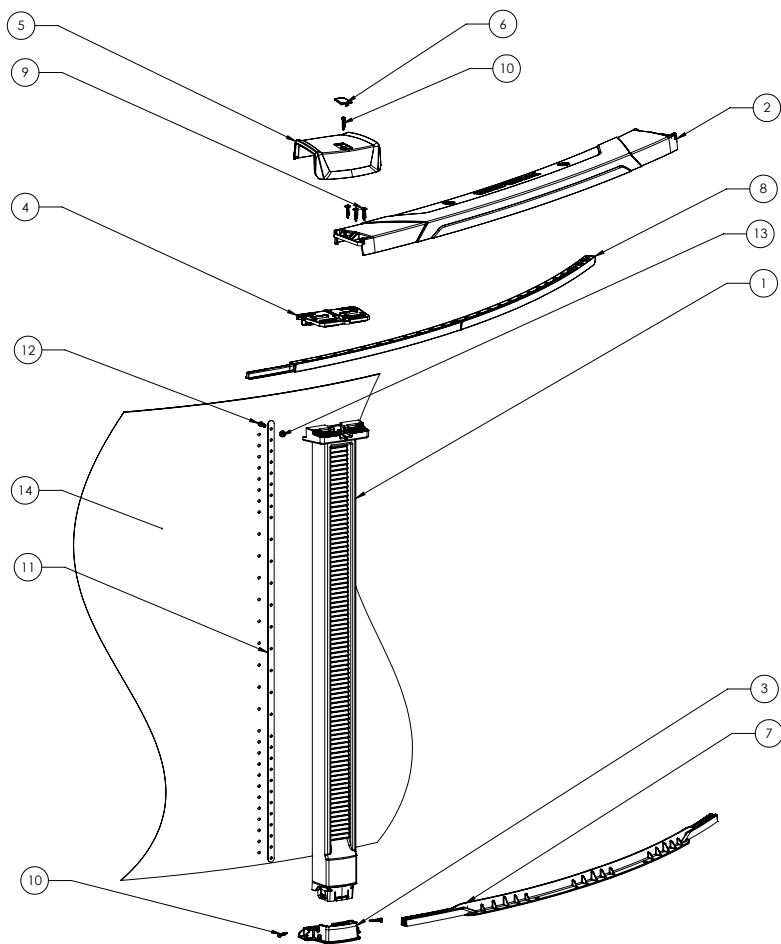

SERIES 3 Model 300								
No.	PART CODE	DESCRIPTION	QUANTITY PER SIZE					
			12'	15'	18'	21'	24'	27'
1	45930006	S300 UPRIGHT 52"	8	10	12	14	16	18
	45820006	S300 UPRIGHT 54"	8	10	12	14	16	18
2	45640006	S300 TOP LEDGE	8	10	12	14	16	18
3+4+5	45751006	<b>S300 KIT (3 PARTS)</b>						
		- S300 BOTTOM PLATE	8	10	12	14	16	18
		- S300 TOP PLATE	8	10	12	14	16	18
		- S300 TOP LEDGE COVER	8	10	12	14	16	18
6	45471006	S300 LEDGE COVER CAP	8	10	12	14	16	18
7	46026371-BOTTOM	BOTTOM RAIL 15'	8	10	12	-	-	-
	46026361-BOTTOM	BOTTOM RAIL 24'				14	16	18
8	46026371-TOP	TOP RAIL 15'	8	10	12			
	46026361-TOP	TOP RAIL 24'	-	-	-	14	16	18
9	14455110	PAN HEAD HI-LO THREAD SELF TAPPING SCREW W/WASHER 5/8", SS316, #12-14 X 1-1/4"	32	40	48	56	64	72
10	14455032	PAN HEAD SELF DRILLING SCREW, SS316, #12-14 X 1-1/4"	32	40	48	56	64	72
11	02581536	WALL BRACKET 52"	2	2	2	2	2	2
	02581541	WALL BRACKET 54"	2	2	2	2	2	2
12	14172209	PAN HEAD MACHINE SCREW, 1/4"-20 X 3/4"	52"	30	30	30	30	30
	14172209		54"	32	32	32	32	32
13	14072620	FLANGED NUT, 1/4"-20 X 5/16"	52"	30	30	30	30	30
	14072620		54"	32	32	32	32	32
POOL WALL								
No.	PALOMA (MIST) 52"	POOL SIZE	12'	15'	18'	21'	24'	27'
14	19310212	12'	1					
	19310215	15'		1				
	19310218	18'			1			
	19310221	21'				1		
	19310224	24'					1	
	19310227	27'						1

Use only genuine SUNLAB™ replacement parts.

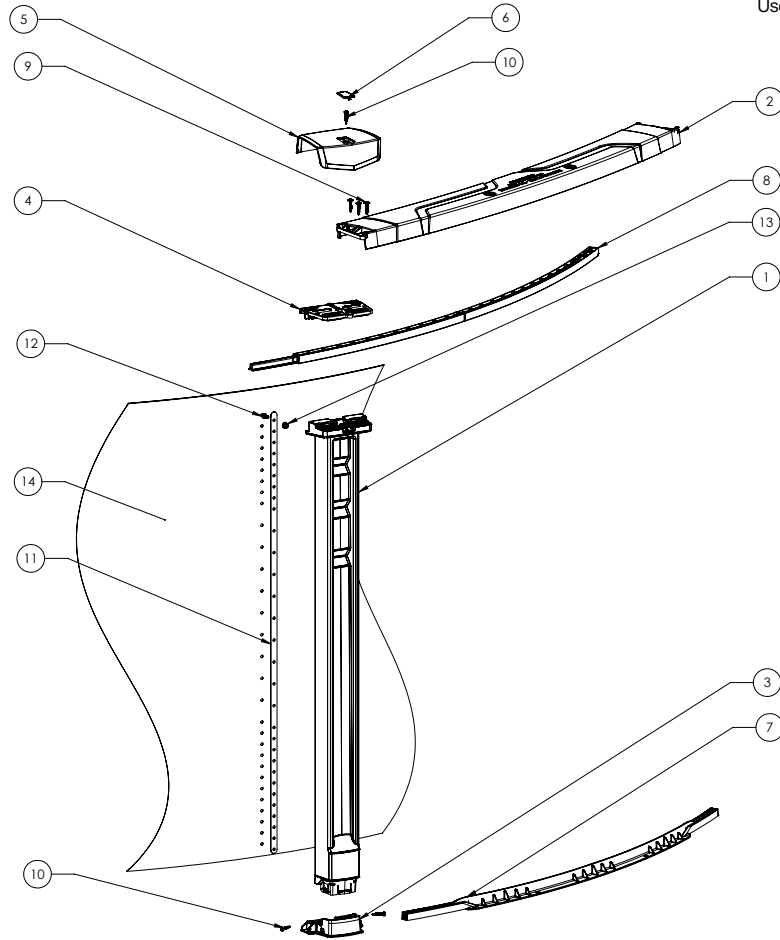

SERIES 3 Model 310								
No.	PART CODE BLACK	DESCRIPTION	QUANTITY PER SIZE					
			12'	15'	18'	21'	24'	27'
1	45091006	S310 UPRIGHT 52"	8	10	12	14	16	18
	45092006	S310 UPRIGHT 54"	8	10	12	14	16	18
2	45182006	S310 TOP LEDGE	8	10	12	14	16	18
3+4+5	45274006	<b>S310 KIT (3 PARTS)</b>						
		- S310 BOTTOM PLATE	8	10	12	14	16	18
		- S310 TOP PLATE	8	10	12	14	16	18
		- S310 TOP LEDGE COVER	8	10	12	14	16	18
6	45471006	S310 TOP LEDGE COVER CAP	8	10	12	14	16	18
7	46026371-BOTTOM	BOTTOM RAIL 15'	8	10	12	-	-	-
	46026361-BOTTOM	BOTTOM RAIL 24'				14	16	18
8	46026371-TOP	TOP RAIL 15'	8	10	12			
	46026361-TOP	TOP RAIL 24'	-	-	-	14	16	18
9	14455110	PAN HEAD HI-LO THREAD SELF TAPPING SCREW W/WASHER 5/8", SS316, #12-14 X 1-1/4"	32	40	48	56	64	72
10	14455032	PAN HEAD SELF DRILLING SCREW, SS316, #12-14 X 1-1/4"	32	40	48	56	64	72
11	02581536	WALL BRACKET 52"	2	2	2	2	2	2
	02581541	WALL BRACKET 54"	2	2	2	2	2	2
12	14172209	PAN HEAD MACHINE SCREW, 1/4"-20 X 3/4"	52"	30	30	30	30	30
			54"	32	32	32	32	32
13	14072620	FLANGED NUT, 1/4-20 X 5/16"	52"	30	30	30	30	30
			54"	32	32	32	32	32
POOL WALL								
No.	SPRITZ (STRIA) 52"	POOL SIZE	12'	15'	18'	21'	24'	27'
14	19300112	12'	1					
	19300115	15'		1				
	19300118	18'			1			
	19300121	21'				1		
	19300124	24'					1	
	19300127	27'						1

Use only genuine SUNLAB™ replacement parts.

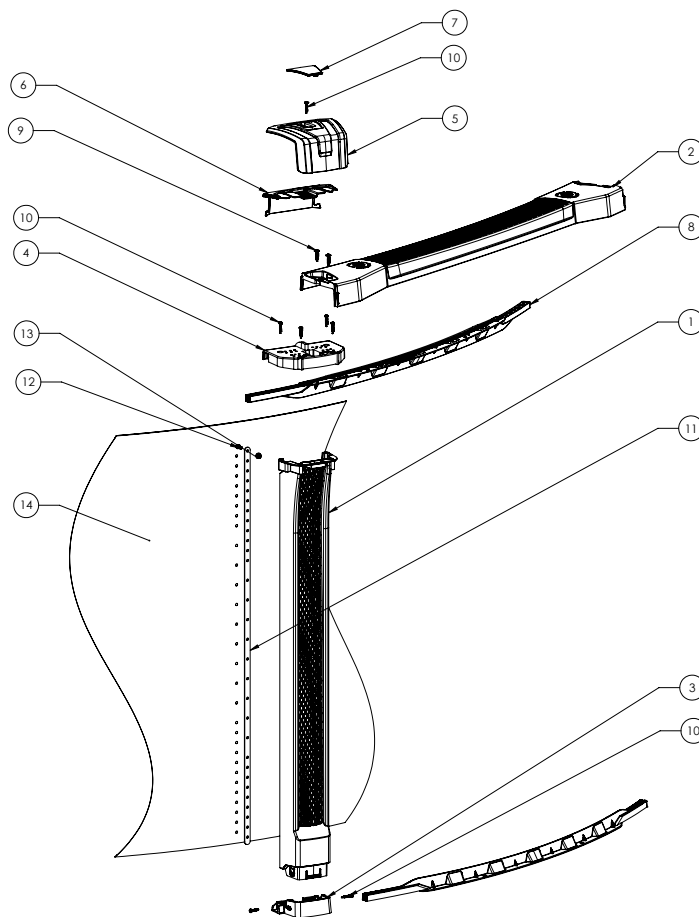
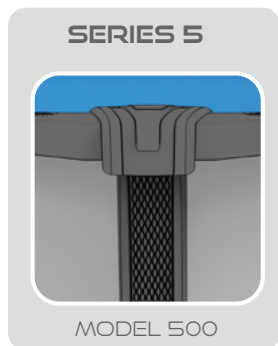

SERIES 5 Model 500										
No.	PART CODE	DESCRIPTION	QUANTITY PER SIZE							
	BLACK		12'	15'	18'	21'	24'	27'	30'	33'
1	45123006	S500 UPRIGHT 52"	8	10	12	14	16	18	20	22
	45124006	S500 UPRIGHT 54"	8	10	12	14	16	18	20	22
2	45234006	S500 TOP LEDGE	8	10	12	14	16	18	20	22
3	46025706	BOTTOM PLATE	8	10	12	14	16	18	20	22
4	46077506	TOP PLATE	8	10	12	14	16	18	20	22
5+6	45389006R1	<b>S500 KIT (2 PARTS)</b>								
		S500 TOP LEDGE COVER (FRONT & REAR COVER)	8	10	12	14	16	18	20	22
7	45367006	S500 TOP LEDGE COVER CAP	8	10	12	14	16	18	20	22
8	46026315	RAIL 15'	16	20	24	-	-	-	-	-
	46026324	RAIL 24'	-	-	-	28	32	36	-	-
	46026330	RAIL 30'	-	-	-	-	-	-	40	44
9	14455110	PAN HEAD HI-LO THREAD SELF TAPPING SCREW W/WASHER 5/8", SS316, #12-14 X 1-1/4"	32	40	48	56	64	72	80	88
10	14455032	PAN HEAD SELF DRILLING SCREW, SS316, #12-14 X 1-1/4"	56	70	84	98	112	126	140	154
11	02581536	WALL BRACKET 52"	2	2	2	2	2	2	2	2
	02581541	WALL BRACKET 54"	2	2	2	2	2	2	2	2
12	14172209	PAN HEAD MACHINE SCREW, 1/4"-20 X 3/4"	52"	30	30	30	30	30	30	30
			54"	32	32	32	32	32	32	32
13	14072620	FLANGED NUT, 1/4-20 X 5/16"	52"	30	30	30	30	30	30	30
			54"	32	32	32	32	32	32	32

POOL WALL										
No.	BELLINI (PANELO) 52"	POOL SIZE	12' 15' 18' 21' 24' 27' 30' 33'							
			12'	15'	18'	21'	24'	27'	30'	33'
14	19500412	12'	1							
	19500415	15'		1						
	19500418	18'			1					
	19500421	21'				1				
	19500424	24'					1			
	19500427	27'						1		
	19500430	30'							1	
	19500433	33'								1

Use only genuine SUNLAB™ replacement parts.

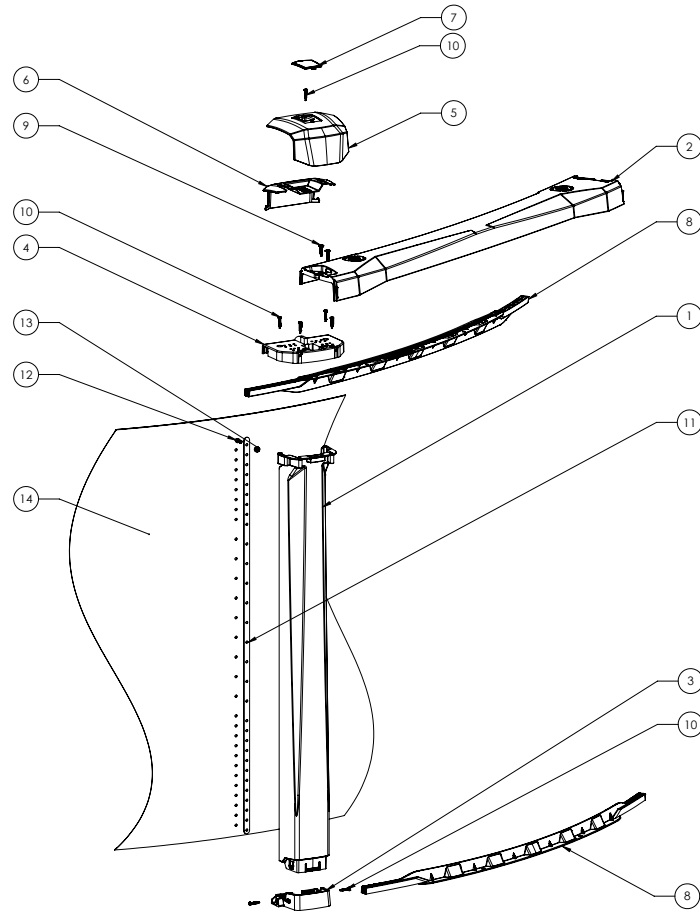

SERIES 5 Model 510											
No.	PART CODE	DESCRIPTION	QUANTITY PER SIZE								
	BLACK		12'	15'	18'	21'	24'	27'	30'	33'	
1	45151006	S510 UPRIGHT 52"	8	10	12	14	16	18	20	22	
	45153006	S510 UPRIGHT 54"	8	10	12	14	16	18	20	22	
2	45263206	S510 TOP LEDGE	8	10	12	14	16	18	20	22	
3	46025706	BOTTOM PLATE	8	10	12	14	16	18	20	22	
4	46077506	TOP PLATE	8	10	12	14	16	18	20	22	
<b>S510 KIT (2 PARTS)</b>											
5+6	45387006R1	S510 TOP LEDGE COVER (FRONT & REAR COVER)	8	10	12	14	16	18	20	22	
7	45384006	S510 TOP LEDGE COVER CAP	8	10	12	14	16	18	20	22	
8	46026315	RAIL 15'	16	20	24	-	-	-	-	-	
	46026324	RAIL 24'	-	-	-	28	32	36	-	-	
	46026330	RAIL 30'	-	-	-	-	-	-	40	44	
9	14455110	PAN HEAD HI-LO THREAD SELF TAPPING SCREW W/WASHER 5/8", SS316, #12-14 X 1-1/4"	32	40	48	56	64	72	80	88	
10	14455032	PAN HEAD SELF DRILLING SCREW, SS316, #12-14 X 1-1/4"	56	70	84	98	112	126	140	154	
11	02581536	WALL BRACKET 52"	2	2	2	2	2	2	2	2	
	02581541	WALL BRACKET 54"	2	2	2	2	2	2	2	2	
12	14172209	PAN HEAD MACHINE SCREW, 1/4"-20 X 3/4"	52"	30	30	30	30	30	30	30	30
			54"	32	32	32	32	32	32	32	30
13	14072620	FLANGED NUT, 1/4-20 X 5/16"	52"	30	30	30	30	30	30	30	30
			54"	32	32	32	32	32	32	32	32

POOL WALL											
No.	ST. GERMAIN (NORDIKWOOD) 52"	ST. GERMAIN (NORDIKWOOD) 54"	POOL SIZE	12'	15'	18'	21'	24'	27'	30'	33'
14	19510312	19595312	12'	1							
	19510315	19595315	15'		1						
	19510318	19595318	18'			1					
	19510321	19595321	21'				1				
	19510324	19595324	24'					1			
	19510327	19595327	27'						1		
	19510330	19595330	30'							1	
	19510333	19595333	33'								1

## CONSUMER INFORMATION

SUNLAB™ retailers or authorized distributors are trained professionals. They are able to answer all your questions. If you encounter a problem that your retailer or distributor is not resolving to your satisfaction, please discuss it with the retailer's or distributor's management. The service manager, general manager or owner can help. Almost all problems are solved this way.

If you are not satisfied with the decision taken by the management of the retailer or distributor, contact SUNLAB™ technical support.

When writing or calling, please provide the following information:

- Product model, serial number and date code;
- Name of the retailer or distributor who sold you the product;
- Original proof of purchase showing date of purchase;
- Your name, address and telephone number;
- A detailed description of the problem; and
- If you are sending an e-mail, include any relevant photos of the product in context in its environment.

## AVAILABILITY OF REPLACEMENT PARTS

Replacement parts are available from your SUNLAB™ dealer or distributor.

## WARRANTY

A digital warranty is provided for your product.

[http://sunlabpool.com/link\\_garantie](http://sunlabpool.com/link_garantie)

## TO OBTAIN A WARRANTY SERVICE

You must first contact your authorized SUNLAB™ dealer or distributor.

Any defect must be reported to an authorized SUNLAB™ dealer or distributor within 72 hours to avoid possible breakage on other equipment, otherwise the guarantee will not be honored.

## TECHNICAL SUPPORT INFORMATION

After contacting your retailer or distributor, if you have any problems with your Product, contact SUNLAB™ technical support.

### AMERICA

Siteweb: [sunlabpool.com](http://sunlabpool.com)

Contact: [Form](#)

Telephone: 1-877-774-6953



Groupe VIF Inc.  
4000, boulevard Casavant West, Saint-Hyacinthe  
Quebec, Canada, J2S 9E3  
[www.sunlabpool.com](http://www.sunlabpool.com)